

A8 3D Printer Installation Guide

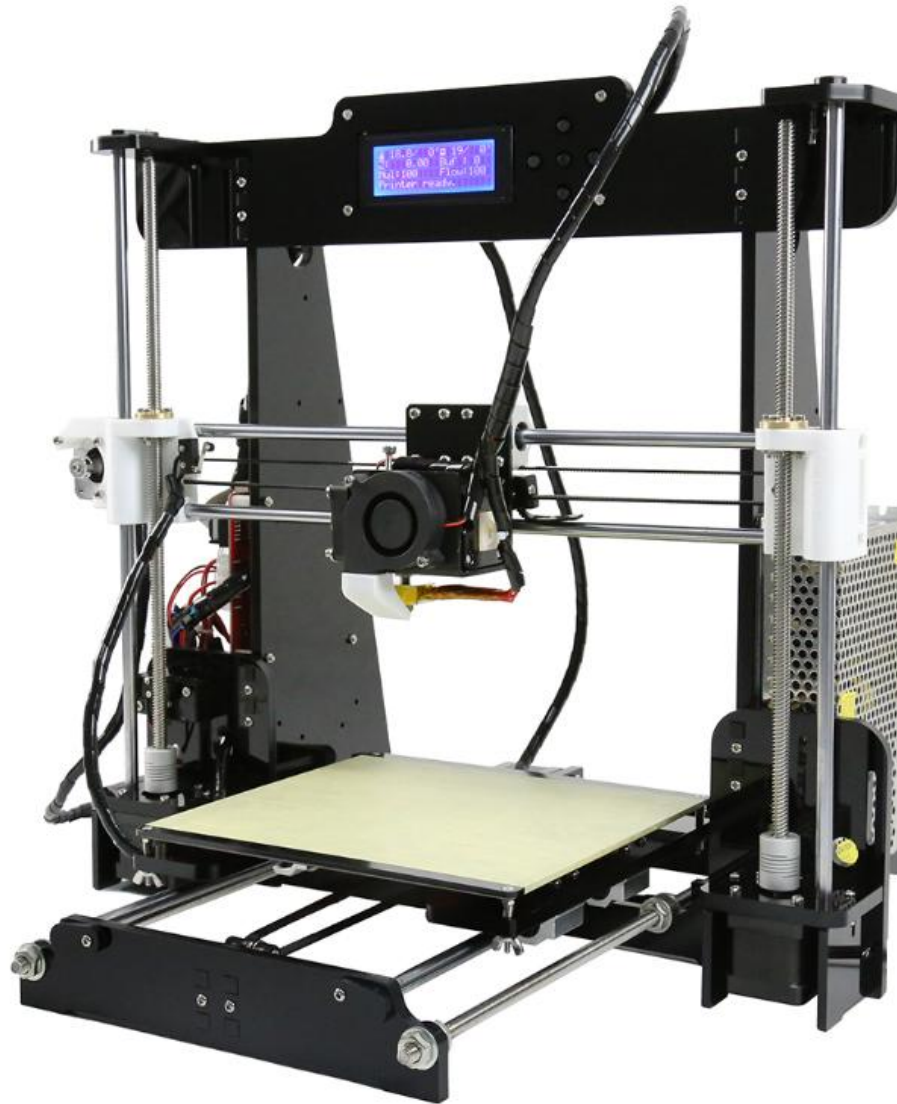









A8 Assembly Instructions

Attention:















- 1. Please make sure the package not broken when you receive it.**
- 2. Please check the printer parts according to the packing list.**
- 3. Please contact your supplier if any questions.**

A8 assembly parts list 1















3D Printer A8 assembly parts list

Item	Picture	Name	QTY	Check	Item	Picture	Name	QTY	Check
1-1		Hot bed fixed aluminum plate	1		2-1		Mainboard	1	
1-2		220mm*220mm*3mm Hot bed	1		2-2		Left Z axis nut support	1	
1-3		Plastic nippers	1		2-3		Right Z axis nut support	1	
1-4		1.5M Power line	1		2-4		Wind mouth	1	
1-5		5mm*160mm Screwdriver	1		2-5		1.6M Belt	1	
1-6		Four parts below in this bag	1		2-6		1.5M USB wire	1	















A8 assembly parts list 2

Item	Picture	Name	QTY	Check	Item	Picture	Name	QTY	Check
1-6-1		40*10 Fan	1		2-7		5015 Air blower	1	
1-6-2		40*11 Cooling fin	1		2-8		Y axis belt bearing support	1	
1-6-3		Fan cover	1		2-9		Seven parts below in this bag	1	
1-6-4		M3*45 Screw 2pcs M3 Spacer 8pcs	1		2-9-1		Z axis Limit switch fixed plate	2	
1-7		Screw bag include below screws	1		2-9-2		Y axis motor support	1	
1-7-1		M3*18 screw 52pcs	1		2-9-3		Y axis Limit switch fixed plate	1	
1-7-2		M3 Nut 64pcs	1		2-9-4		Y axis belt fixation clamp	2	











A8 assembly parts list 3

Item	Picture	Name	QTY	Check	Item	Picture	Name	QTY	Check
1-7-3		M8 Nut 16pcs M8 Spacer 12pcs	1		2-9-5		Guide rod back up plate	6	
1-7-4		M4*8 screw 28pcs M4*14 screw 4pcs	1		2-10		Side support plate	2	
1-7-5		M3*30 screw 14pcs	1		2-11		Filament support plate	2	
1-7-6		M3*12 screw 15pcs	1		2-12		Filament support plate connecting plate	2	
1-7-7		M2*12 screw 4pcs wing nut 4pcs Spring 4pcs	1		2-13		Screen baffle plate	1	
1-7-8		M3*25 screw 3pcs	1		2-14		Z axis motor support Plate	4	
1-8		Three parts below in this bag	1		2-15		8GB TF card and card reader	1	







A8 assembly parts list 4

Item	Picture	Name	QTY	Check	Item	Picture	Name	QTY	Check
1-8-1		Wire 70CM	1		3-1		Bottom support plate	1	
1-8-2		Z axis Limit switch A 20CM X axis Limit switch B 55CM Y axis Limit switch C 70CM	3		3-2		Top support plate	1	
1-8-3		Pillar washer M3*7 4pcs Pillar washer M3*15 4pcs	8		3-3		Back plate	1	
1-9		Three parts below in this bag	1		3-4		Front plate	1	
1-9-1		3mm*130mm Screwdriver	1		3-5		Support plate lock plate	2	
1-9-2		Hex wrench M1.5 Hex wrench M2 Hex wrench M2.5 Hex wrench M3	4		3-6		Z axis motor fixed plate	2	
1-9-3		Open spanner	1		3-7		Y axis motor fixed plate	1	

A8 assembly parts list 5

Item	Picture	Name	QTY	Check	Item	Picture	Name	QTY	Check
1-10		Four parts below in this bag	1		3-8		Extruder	1	
1-10-1		4.5M Winding pipe	1		3-9		X axis motor	1	
1-10-2		Belting	10		3-10		Y axis motor	1	
1-10-3		R clip	3		3-11		Z axis motor	2	
1-10-4		Locating piece	2		3-12		Linear bearing	7	

A8 assembly parts list 6

Item	Picture	Name	QTY	Check	Item	Picture	Name	QTY	Check
1-11		LCD 2004 screen	1		3-13		Guide rod 436mm 2pcs Guide rod 380mm 4pcs	6	
1-12		X Motor line 40CM Y Motor line 40CM Left Z Motor line 40CM Right Z Motor line 90CM Extruder Motor line 90CM	5		3-14		T type lead screw M8*345mm 2pcs Threaded rod M8*400mm 2pcs Threaded rod M8*150mm 1pcs	5	
1-13		Heat bed line 90CM	1		3-15		Power Supply	1	

Please check printer parts quantity when you receive it .

Name of each printer part

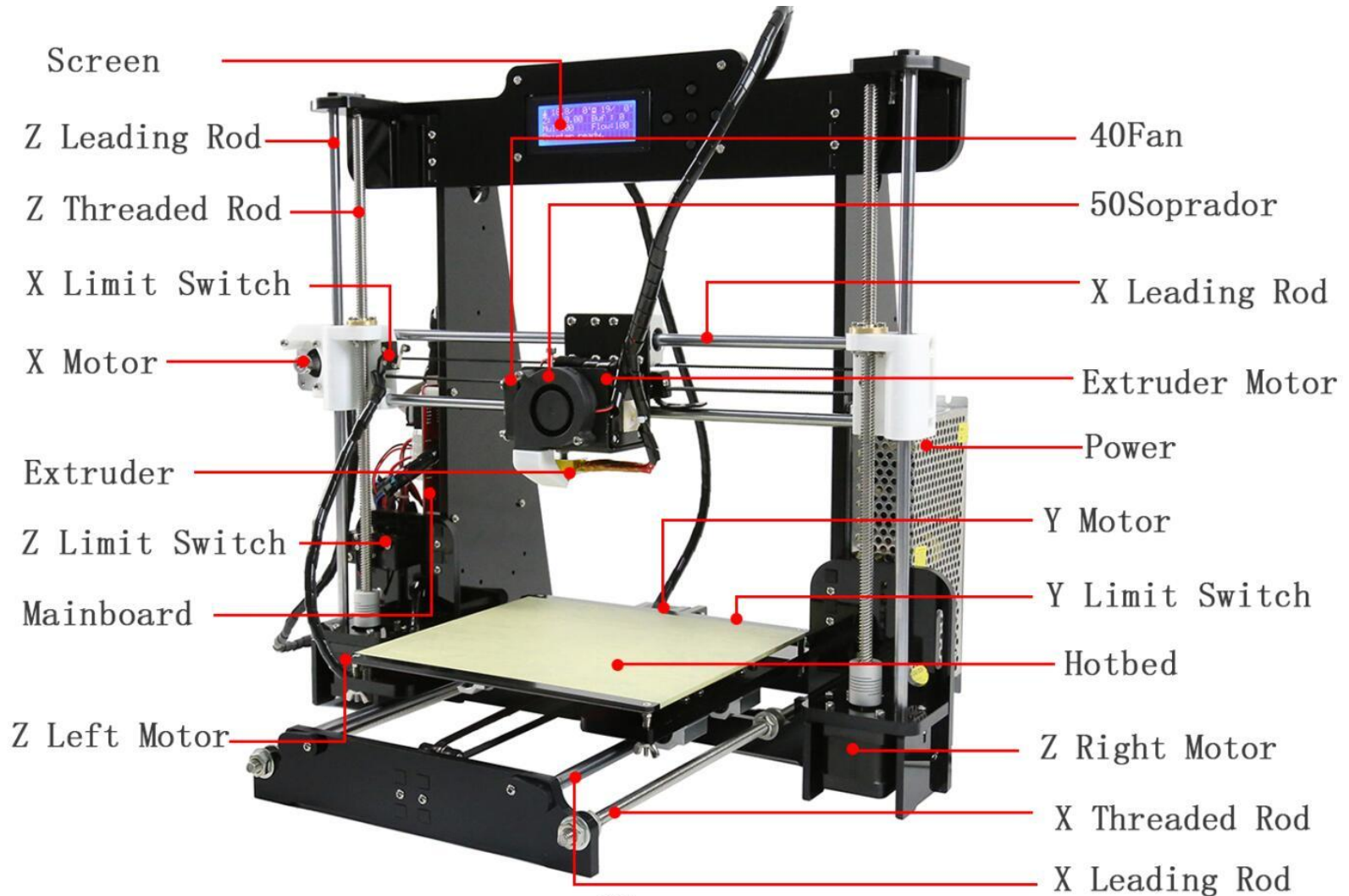

Assembly Step 1

Please be aware the screw holes is in red circles

Name and Qty. of printer parts

Item	Name of parts	QTY.
1	Bottom support plate	1
2	Top support plate	1
3	Side support plate	2
4	M3*18 Screw	12
5	M3 Nut	12



Before Assembly

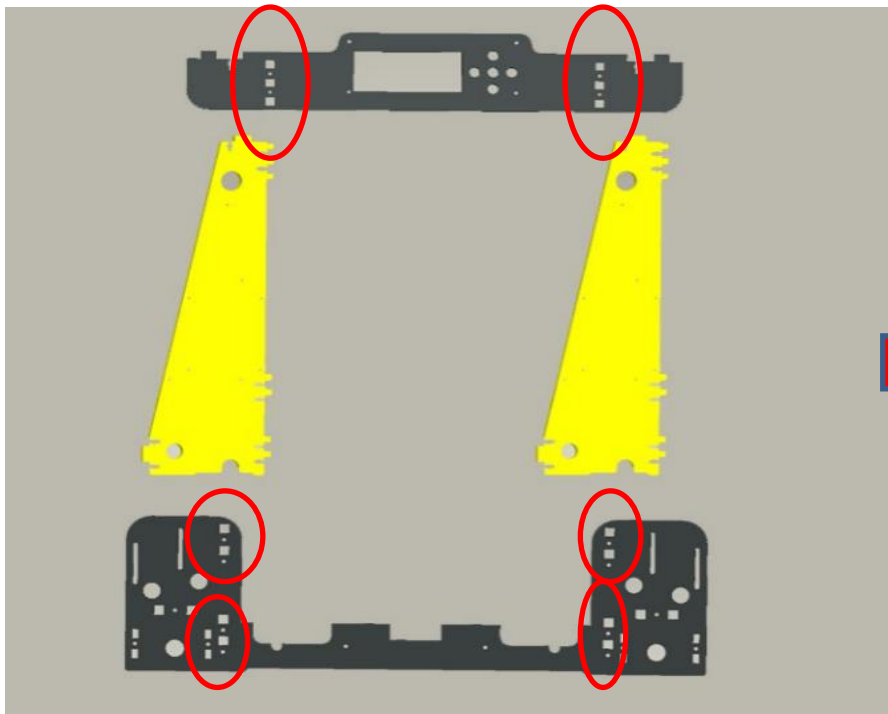

After Assembly

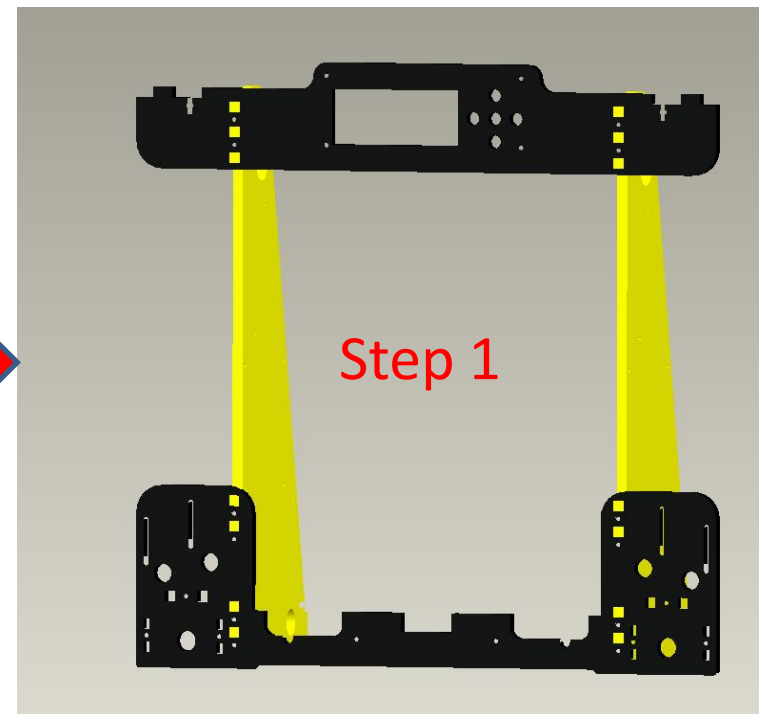

Assembly Step 2

Please be aware the screw holes is in black circles



Name and Qty. of printer parts		
Item	Name of parts	QTY.
1	Step 1	1
2	Support plate lock plate	2
3	M3*18 Screw	4
4	M3 Nut	4

Before Assembly

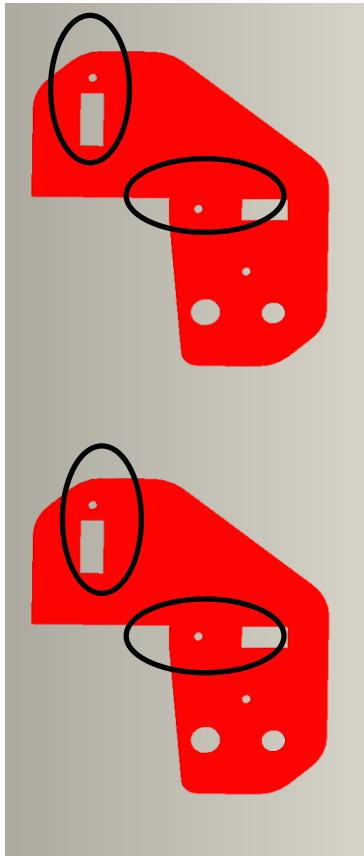

After Assembly

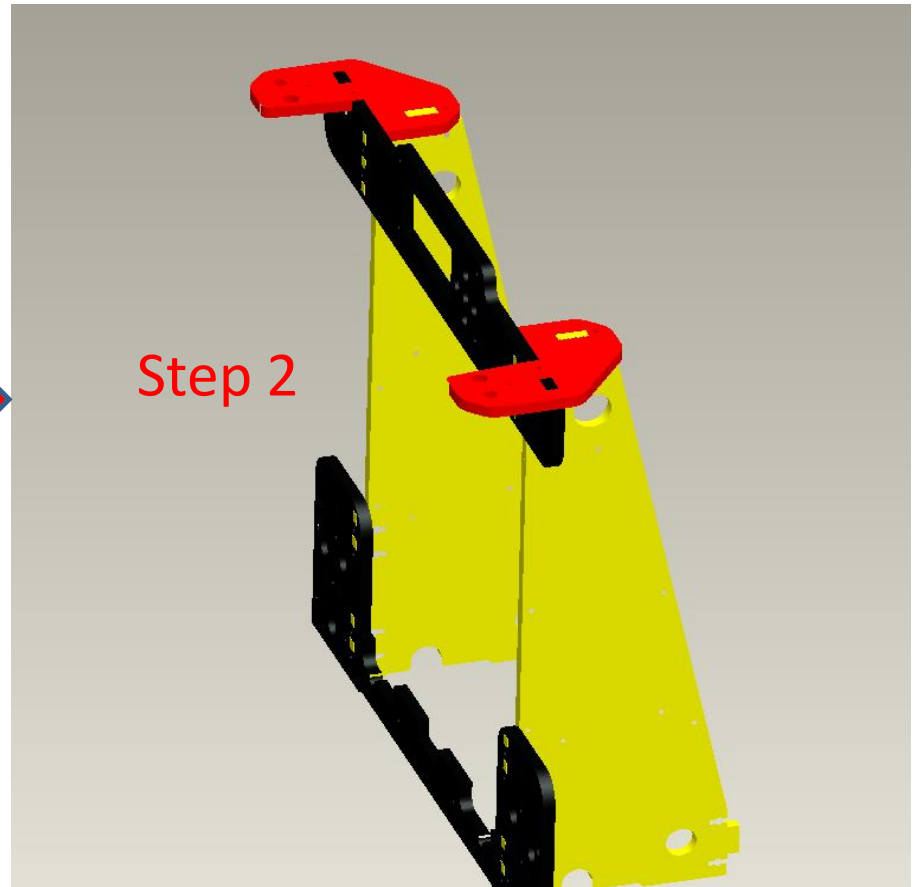

Assembly Step 3



Name and Qty. of printer parts		
Item	Name of parts	QTY.
1	Back plate	1
2	Y axis motor	1
3	Y axis motor support	1
4	Y axis motor fixed plate	1
5	Y axis Limit switch fixed plate	1
6	Y axis Limit switch C 70CM	1
7	M3*12 screw	3
8	M2*12 screw	2
9	M3*18 screw	4
10	M3 Nut	4

Before Assembly

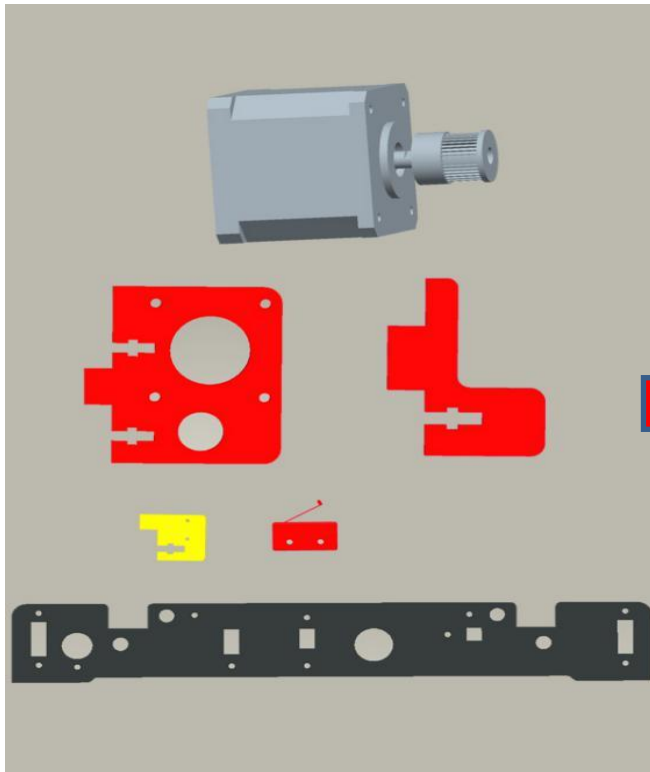

After Assembly

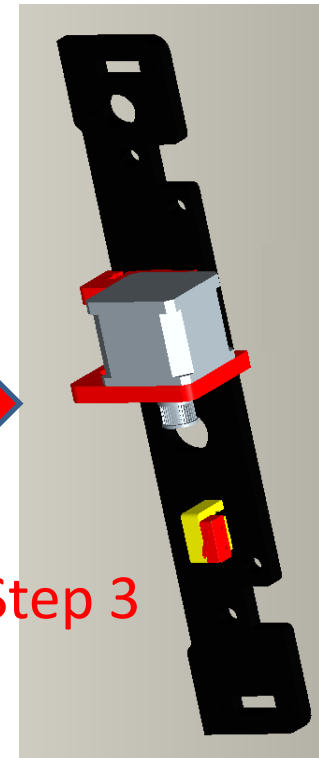
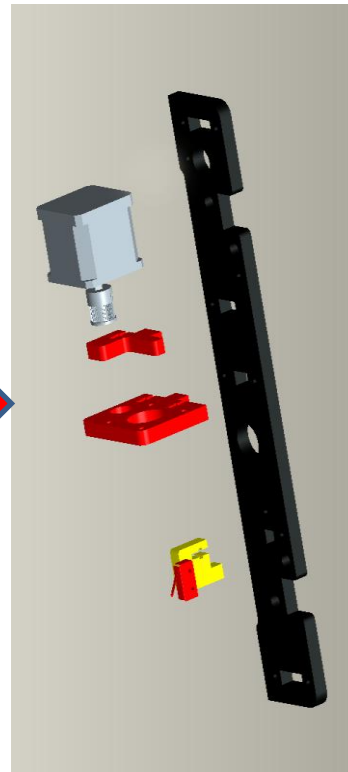

Assembly Step 4

Name and Qty. of printer parts		
Item	Name of parts	QTY.
1	Step 2	1
2	Step 3	1
3	M3*18 screw	4
4	M3 Nut	4



Before Assembly

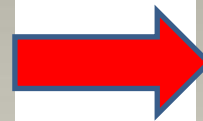
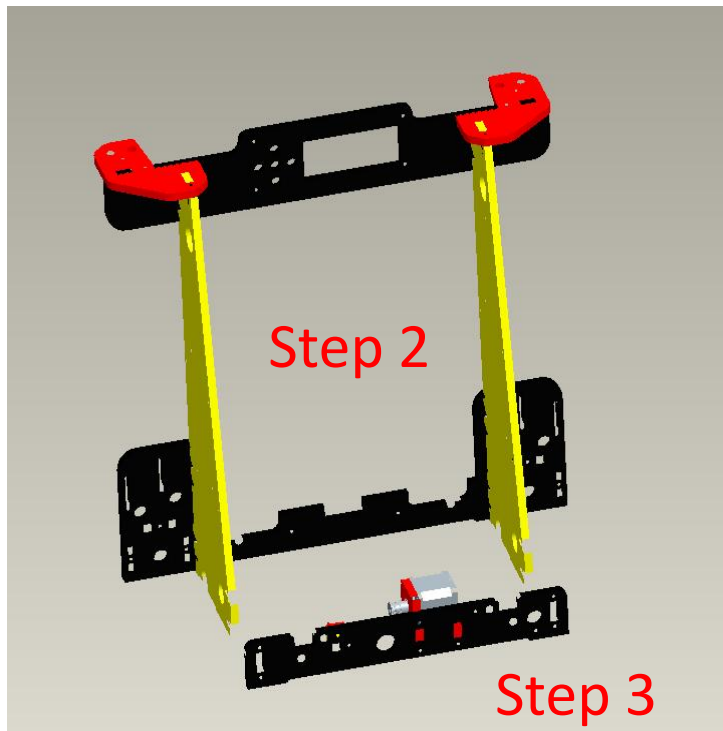

After Assembly

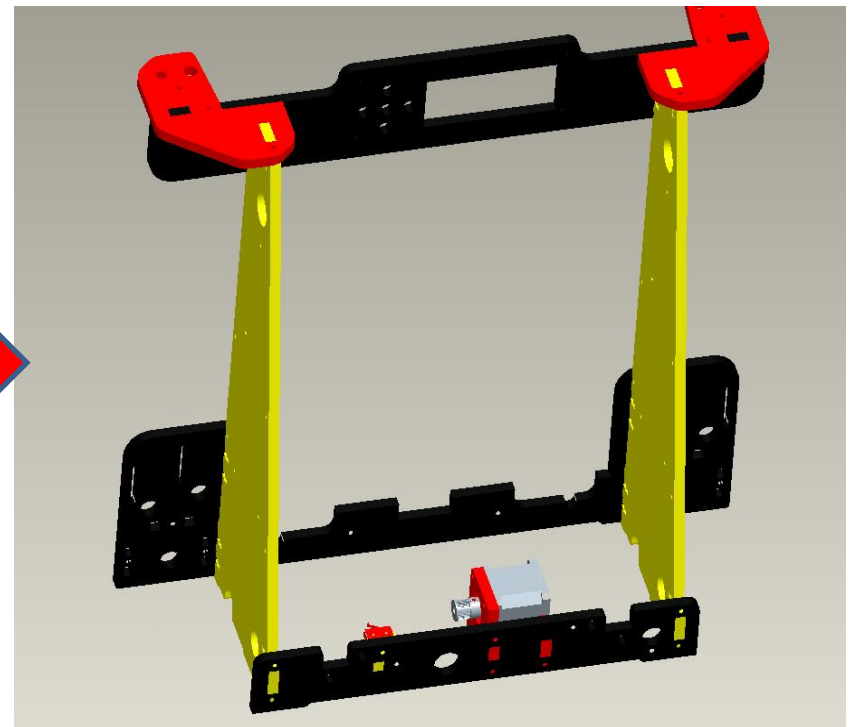

Assembly Step 5

Name and Qty. of printer parts		
Item	Name of parts	QTY.
1	Y axis belt bearing support	1
2	Front plate	1
3	M3*18 screw	2
4	M3 Nut	2



Before Assembly

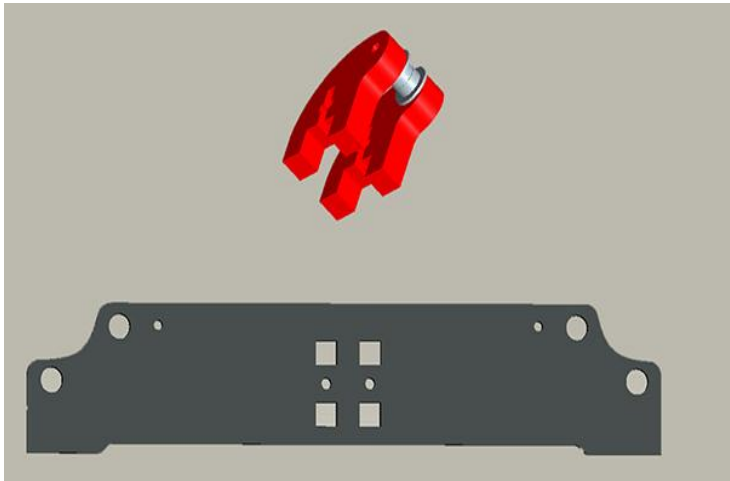

After Assembly

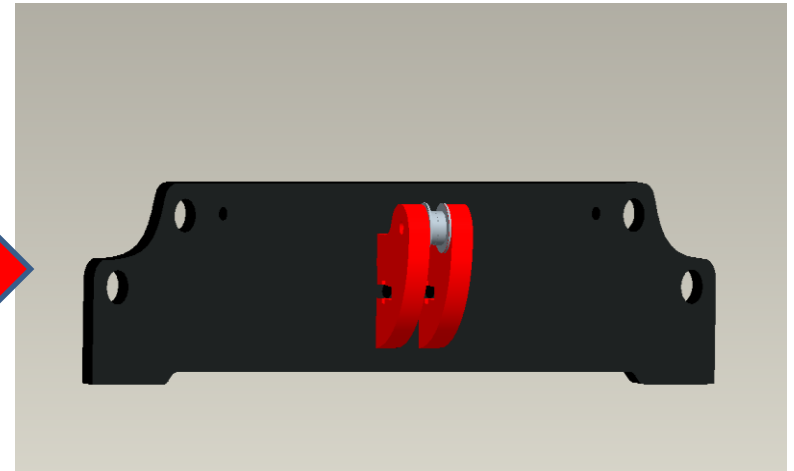

Assembly Step 6

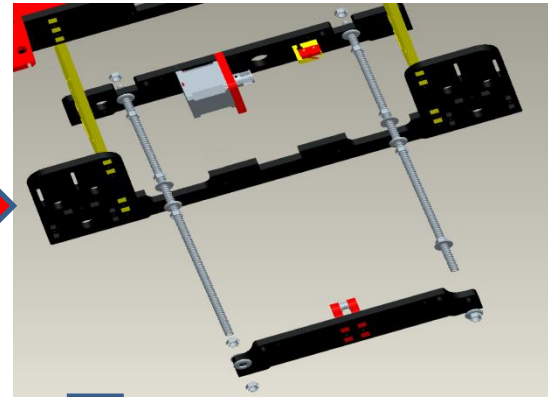
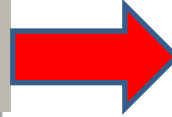
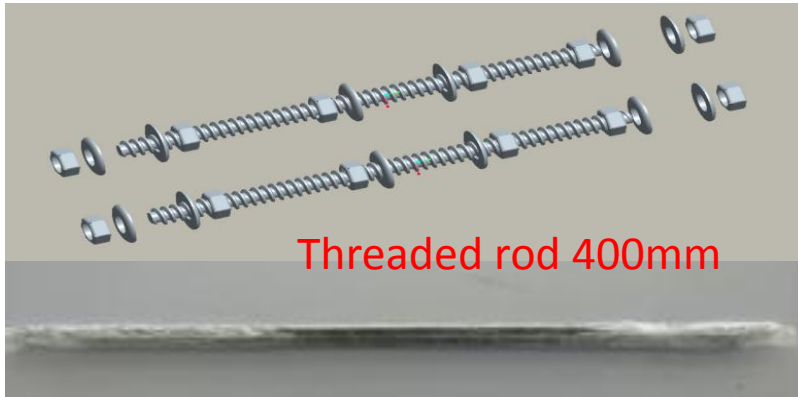

Before Assembly

After Assembly

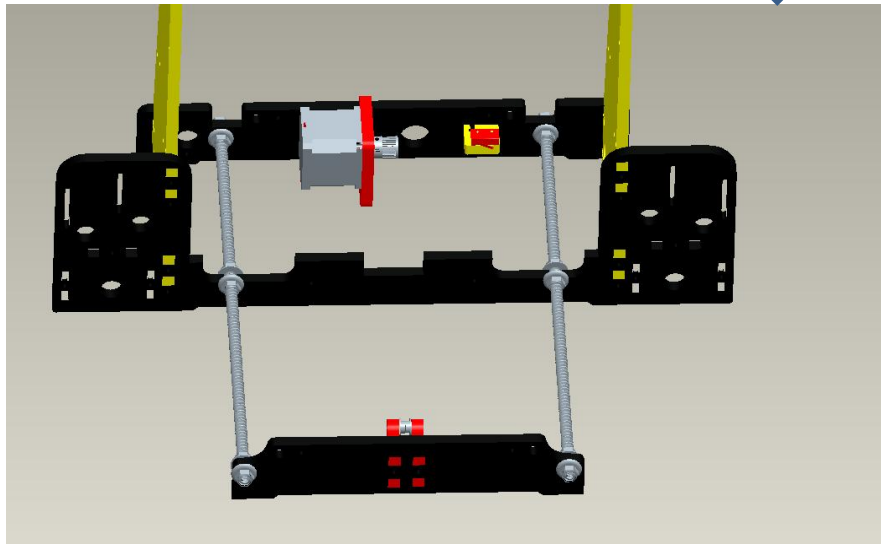

Name and Qty. of printer parts

Item	Name of parts	QTY.
1	Step 4	1
2	Step 5	1
3	Threaded rod 400mm	2
4	M8 Nut	12
5	M8 Spacer	12

Assembly Step 7

Name and Qty. of printer parts

Item	Name of parts	QTY.
1	Step 6	1
2	Y axis Guide rod	2
3	Guide rod back up plate	4
4	Linear bearing	4
5	M3*18 Screw	4
6	M3 Nut	4



Before Assembly

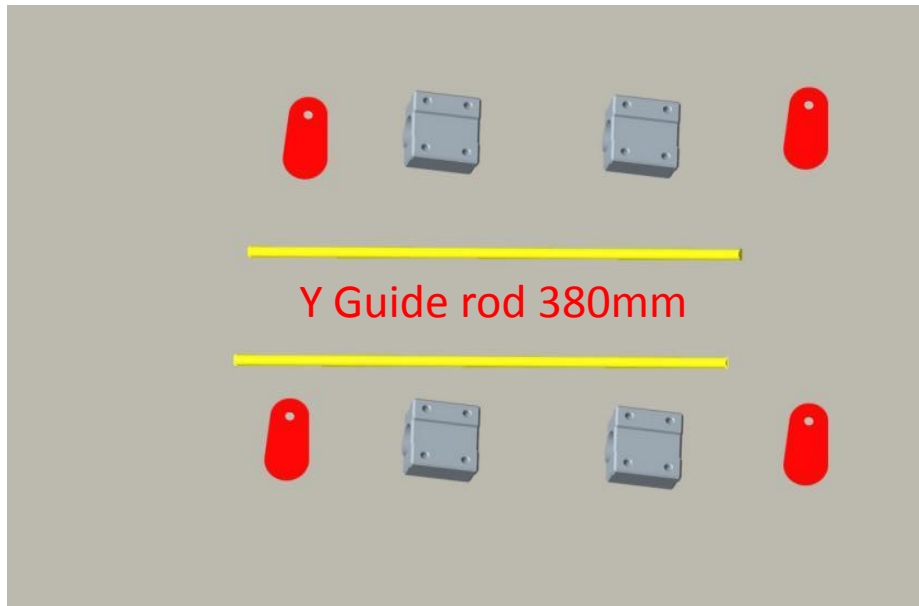

After Assembly

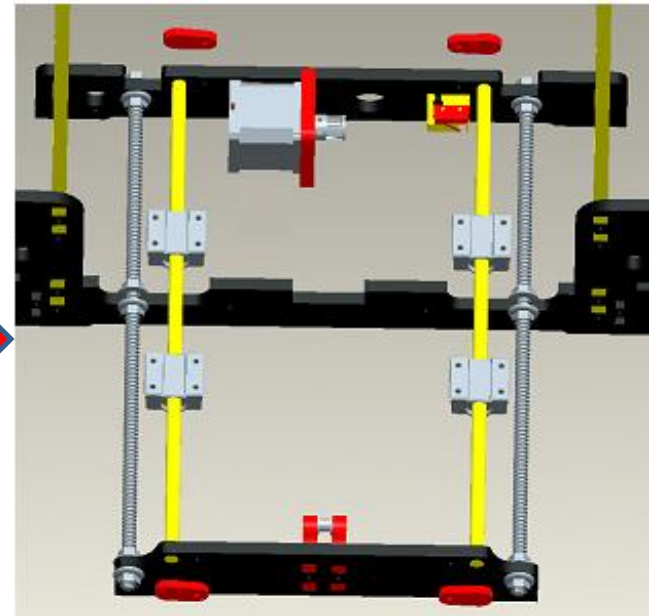

Assembly Step 8



Name and Qty. of printer parts

Item	Name of parts	QTY.
1	Hot bed fixed aluminum plate	1
2	Y axis belt fixation clamp	2
3	M4*14 screw	4

Attention: Leave vacancy between belt fixation clamp and hot bed fixed plate for belt positioning.

Before Assembly

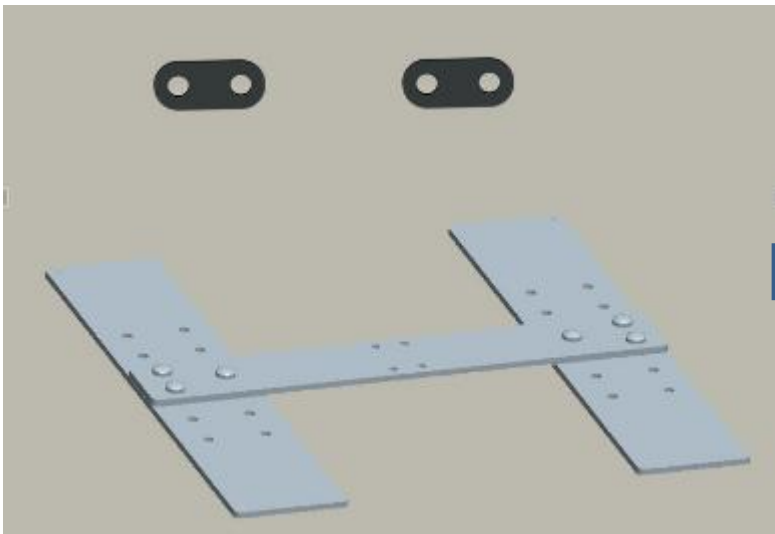

After Assembly

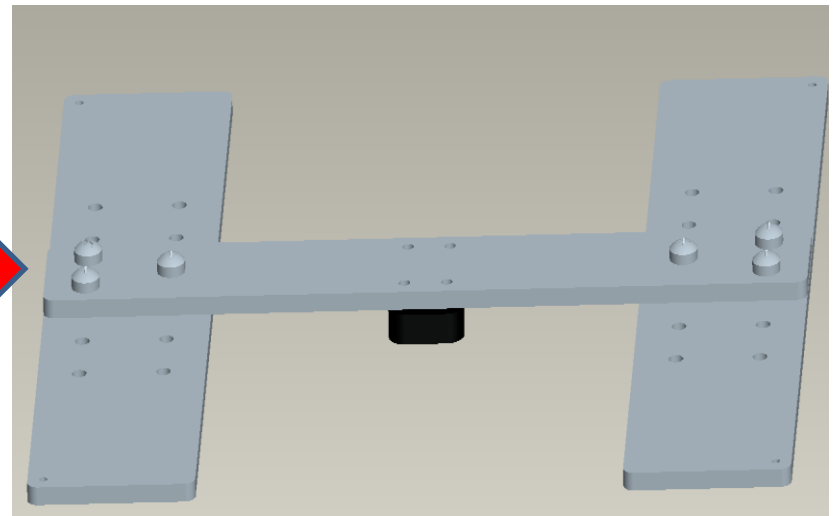

Assembly Step 9



Name of QTY. of printer part

Item	Name of parts	QTY.
1	Step 7	1
2	Step 8	1
3	M4*8 Screw	16

Before Assembly

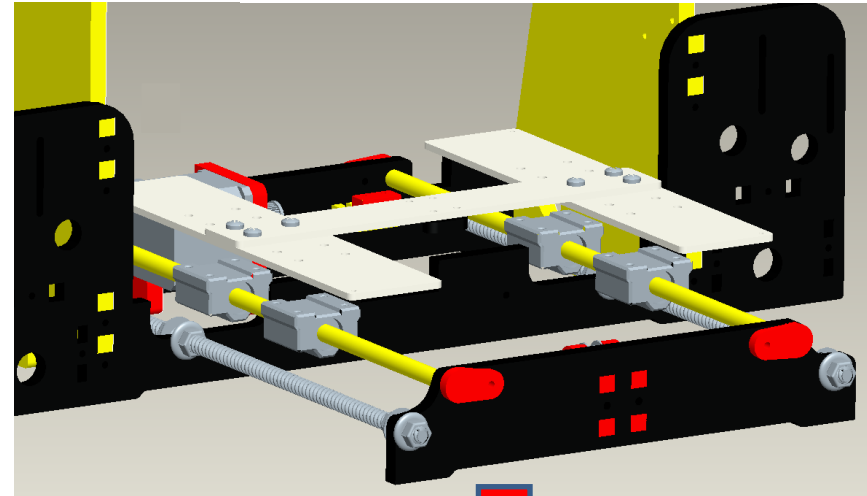
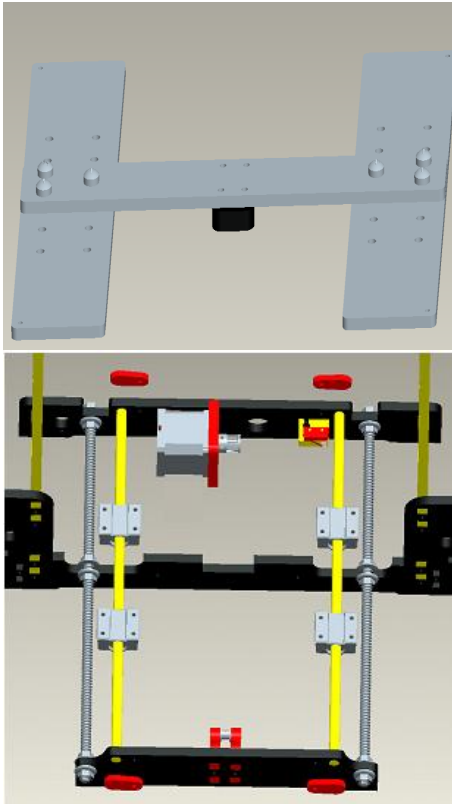

After Assembly

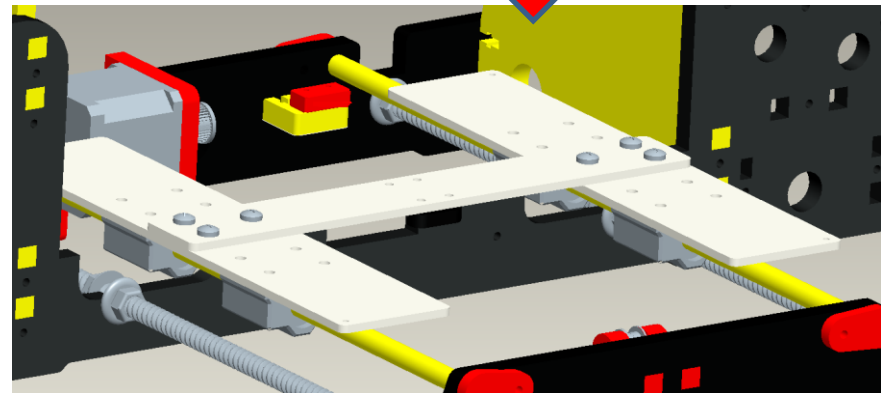

Attention: Please diagonally tighten the screws when all are in there place

Assembly Step 9

Name and Qty. of printer parts

Item	Name of parts	QTY.
1	Belt	1

Before Assembly



After Assembly

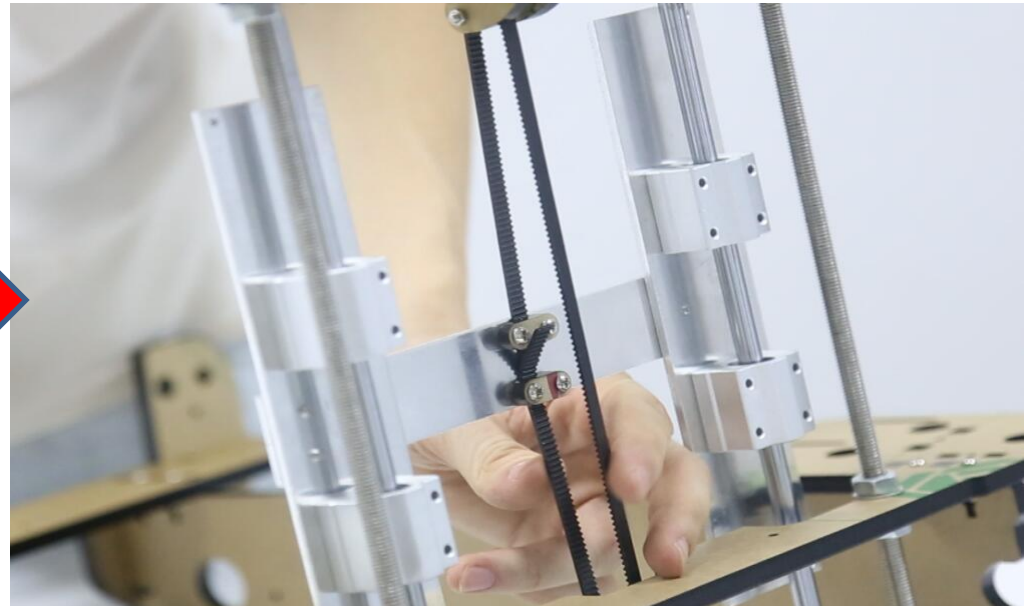

Attention: Belt is for X&Y axis transmitting .Cut the length you need to each transmission shaft. The belt is 1.5m in total and 10-20cm left after installation.

Assembly Step 10

Attention: Hot bed screws should be in the bottom, and wing nuts will keep the height of hot bed level as well as firming the hotbed.

Before Assembly

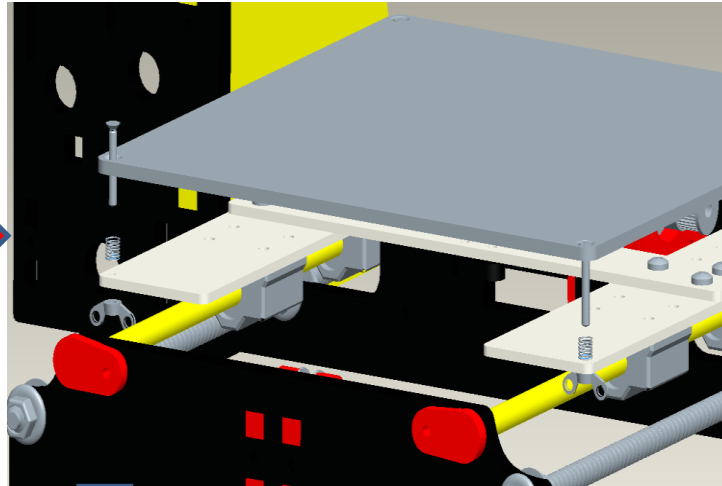
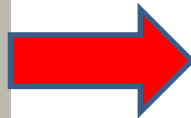
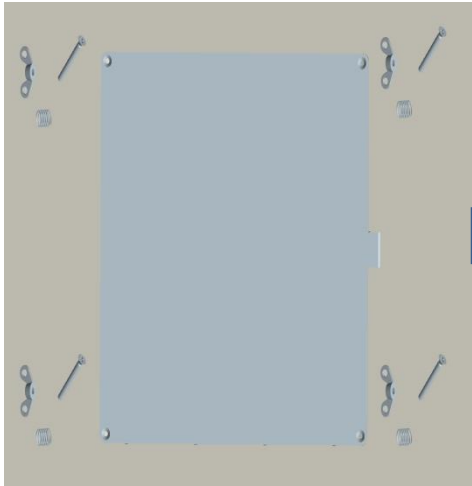

After Assembly

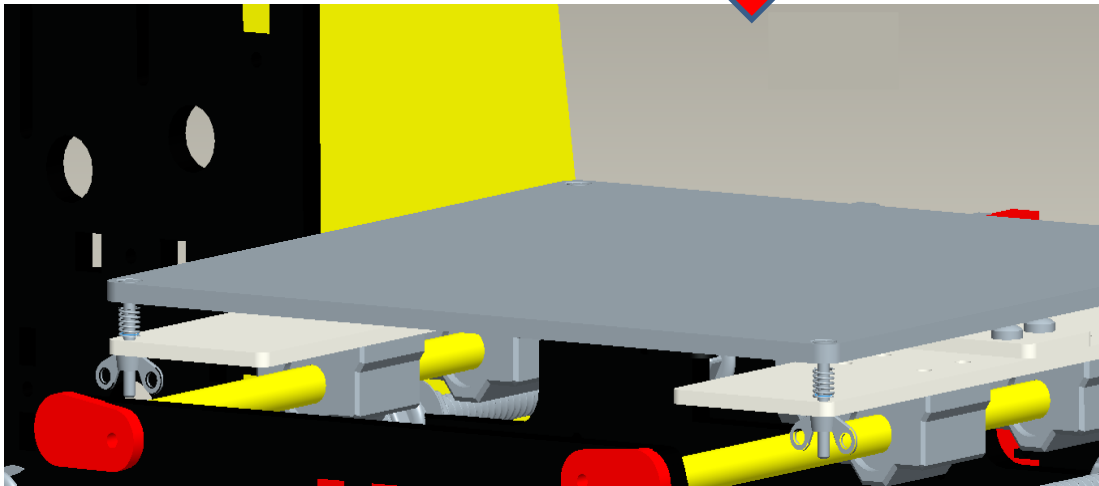

Name and Qty. of printer parts

Item	Name of parts	QTY.
1	Step 9	1
2	Hot bed	1
3	M3*30 Screw	4
4	Spring	4
5	M3 wing nut	4

Assembly Step 11

Attention: This hole is for Z axis guide rod positioning

Before Assembly

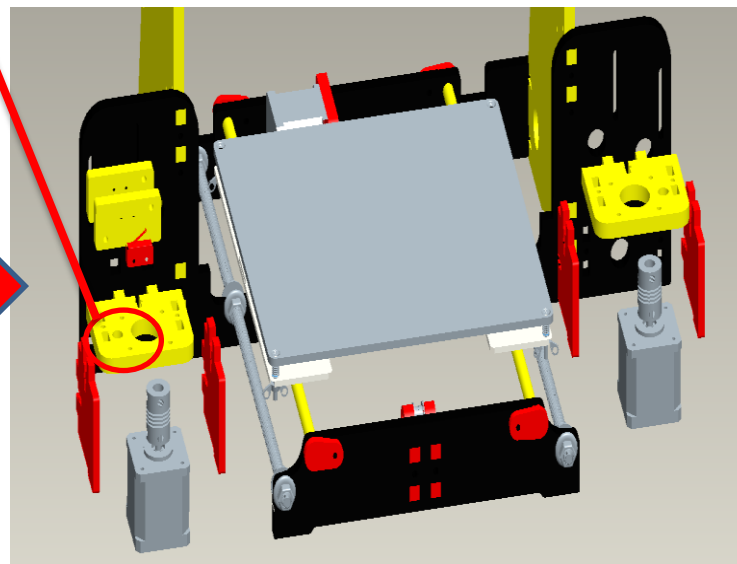
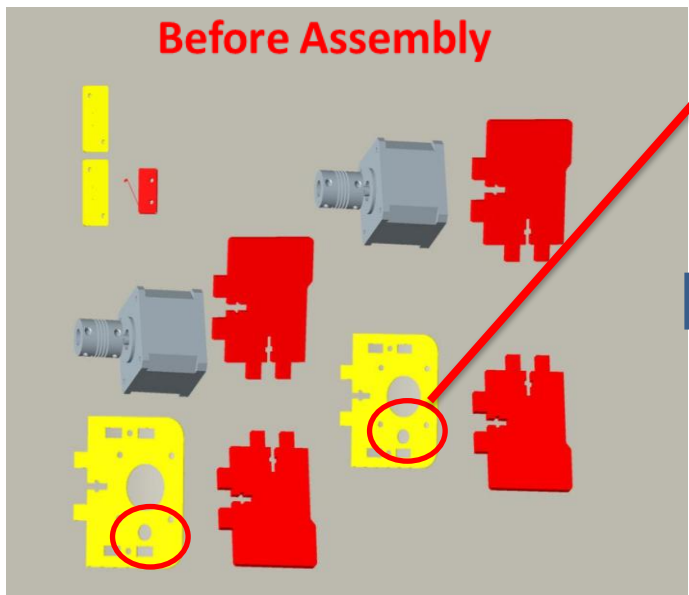

After Assembly

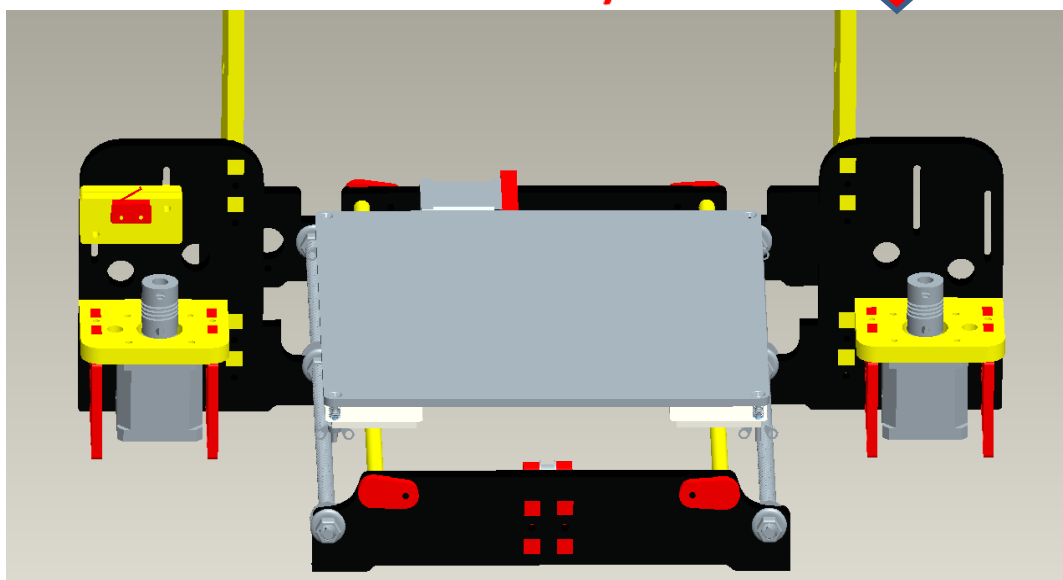

Name and Qty. of printer parts

Item	Name of parts	QTY.
1	Step 10	1
2	Z axis motor	2
3	Z axis motor fixed plate	2
4	Z axis motor support Plate	4
5	Z axis Limit switch fixed plate	2
6	Z axis Limit switch A 20CM	1
7	M3*18 Screw	10
8	M3 Nut	10
9	M3*12 Screw	8

Assembly Step 12

Before Assembly

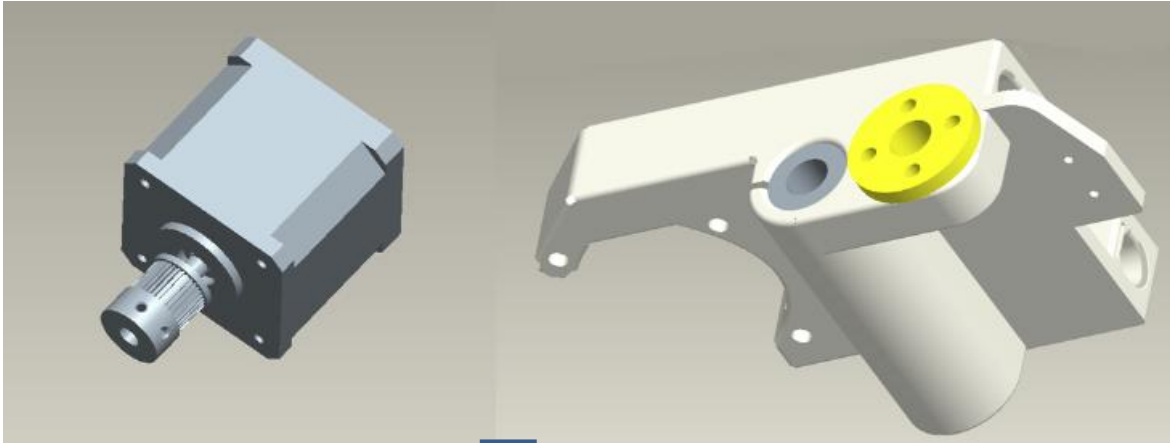

After Assembly

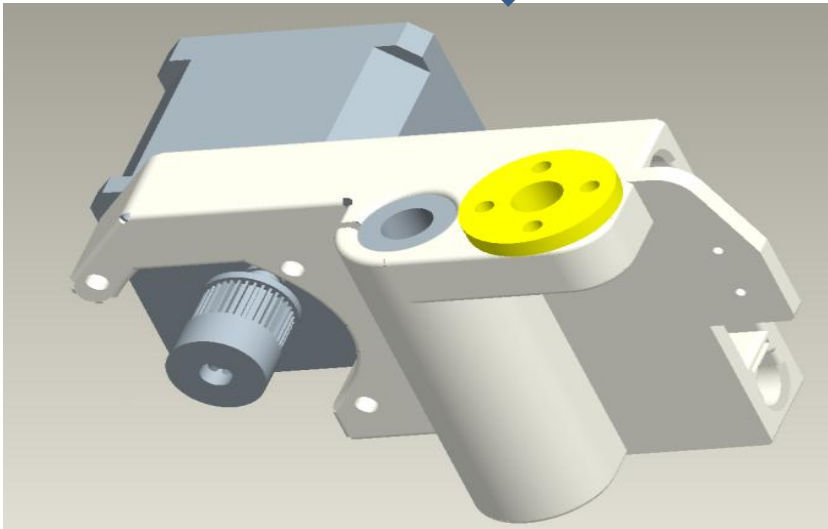

Name and Qty. of printer parts

Item	Name of parts	QTY.
1	X axis motor	1
2	Left Z axis nut support	1
3	M3*25 Screw	3

Assembly Step 13



Before Assembly

Name and Qty. of printer parts

Item	Name of parts	QTY.
1	Step 11	1
2	Step 12	1
3	Right Z axis nut support	1
4	Guide rod back up plate	2
5	Z axis Guide rod 380mm	2
6	M3*18 screw	2
7	M3 Nut	2

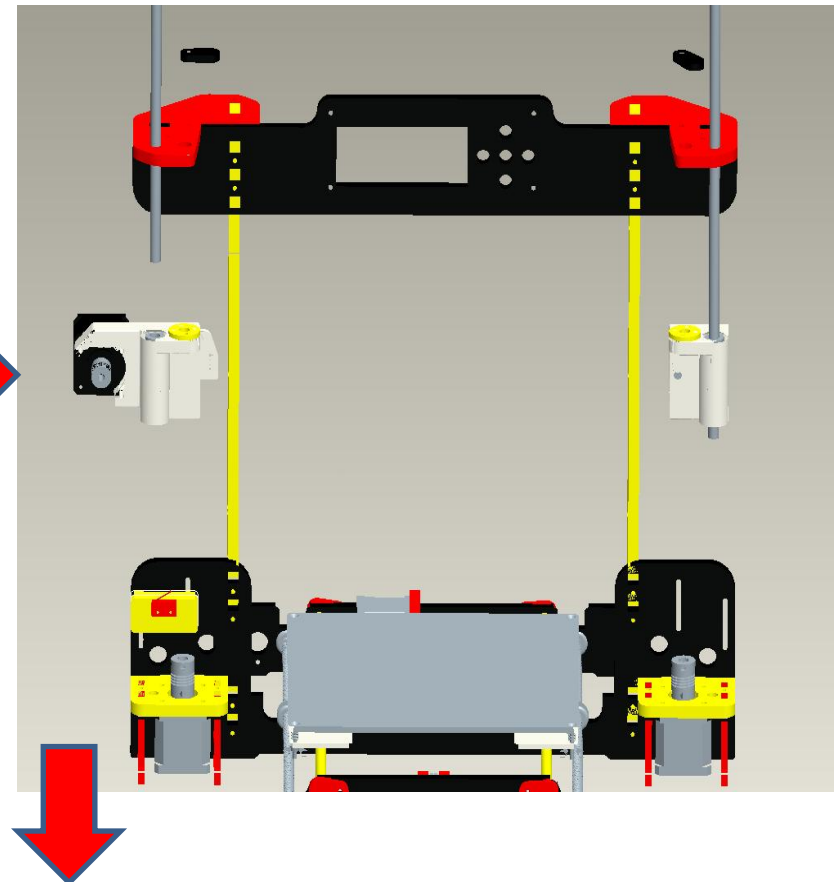
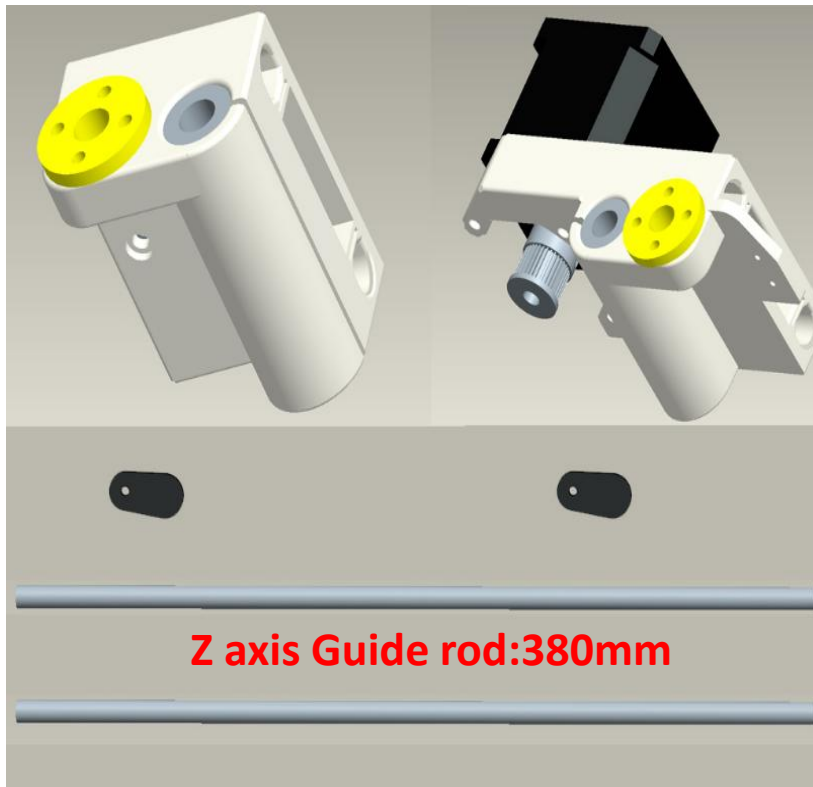

Assembly Step 13

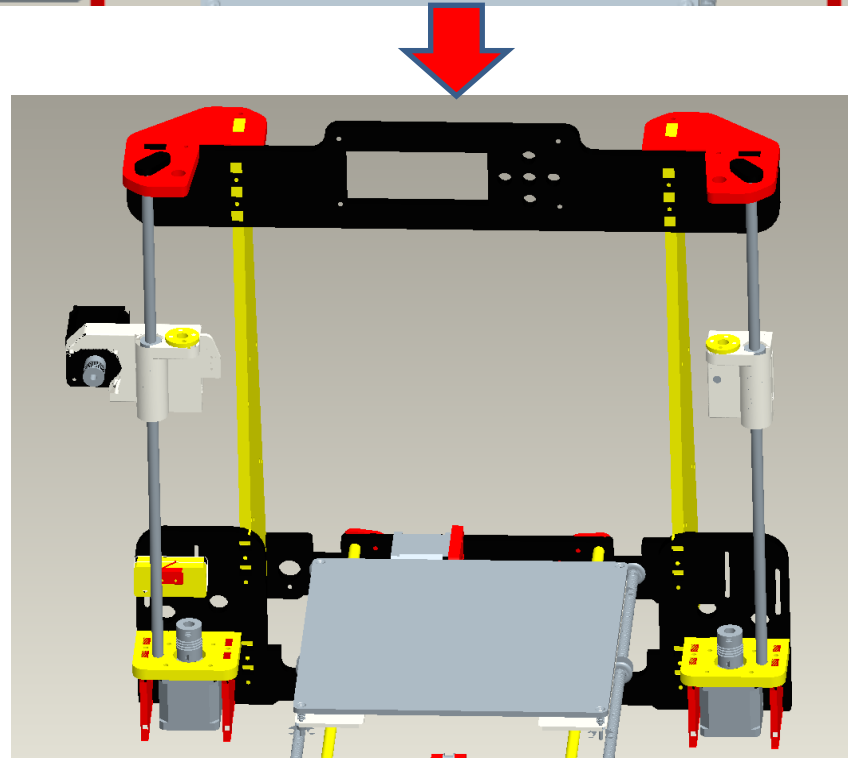
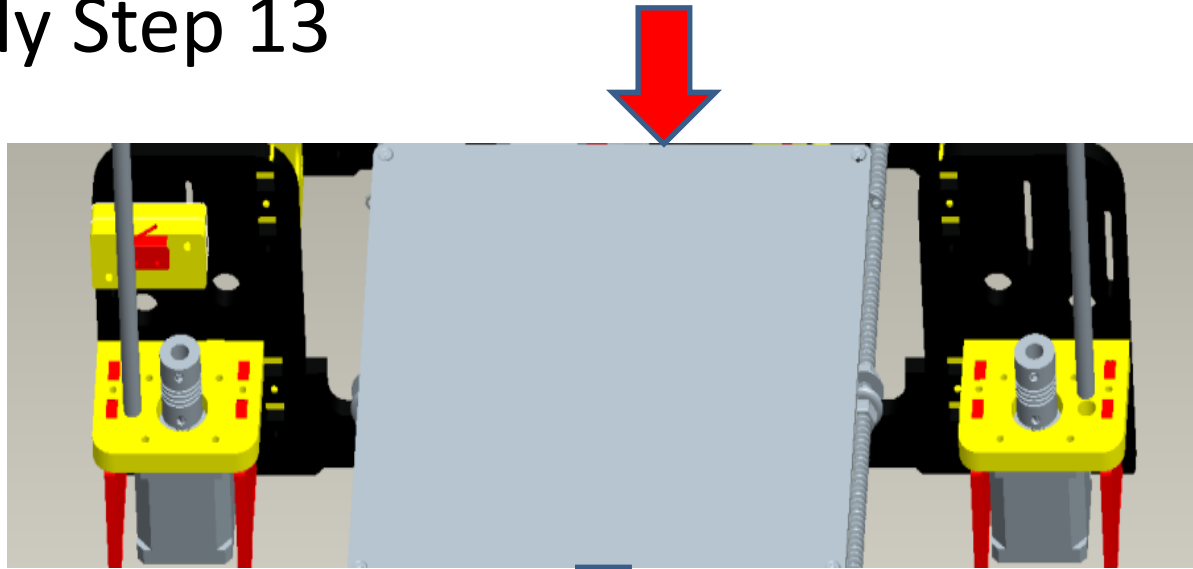

After Assembly

Assembly Step 14

Before Assembly

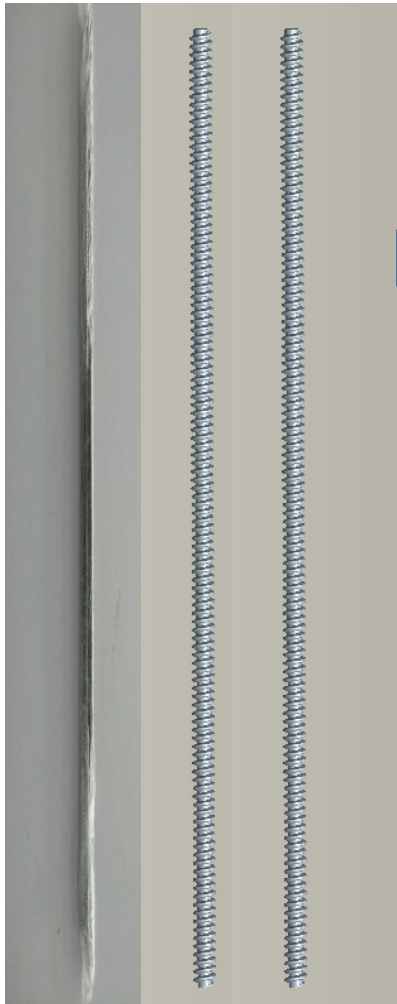

T lead screw 345mm

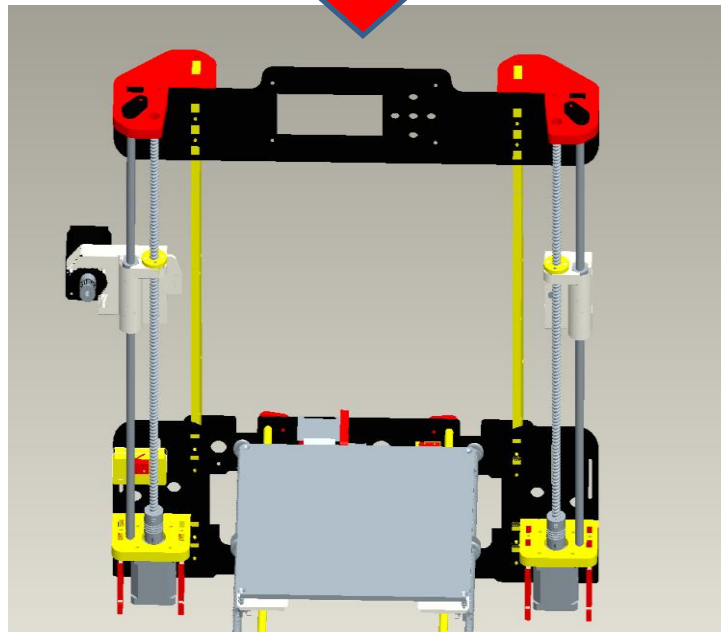
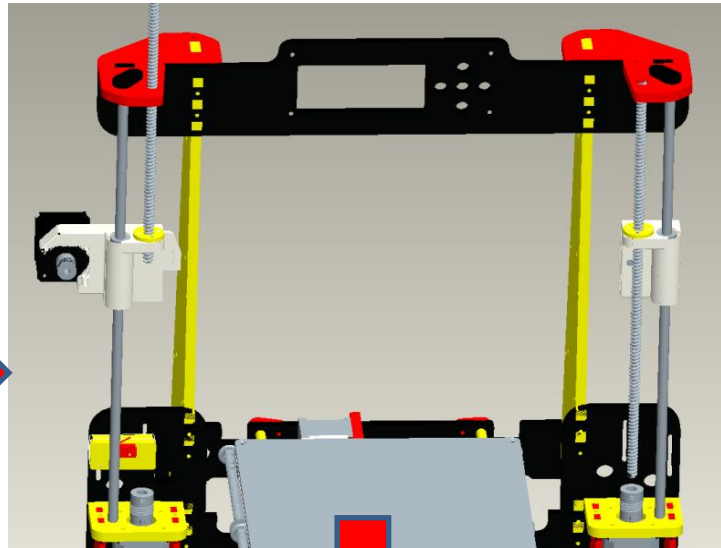

After Assembly

Name and Qty. of printer parts

Item	Name of parts	QTY.
1	Step 13	1
2	T type lead screw 345mm	2

Attention: loose the jackscrew of elastic coupling to place T lead screw to the bottom, then tighten the jackscrew.

Assembly Step 15

Attention: Please keep A&B at the same level during X rods installation. Knock the guide rods with a hammer slightly if it's hard to place.

X axis Guide rod 436mm

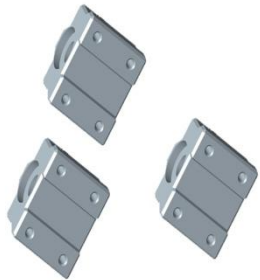

Before Assembly

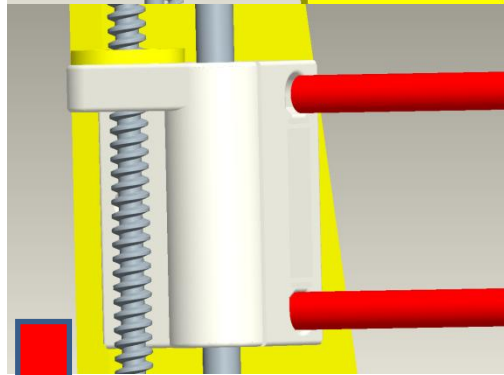
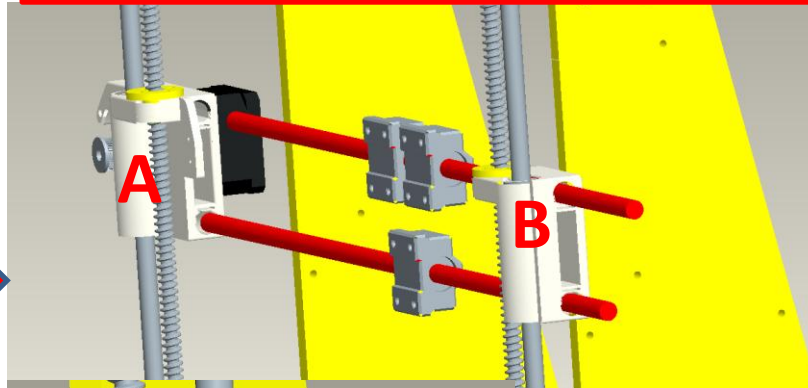
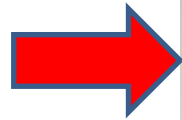

After Assembly

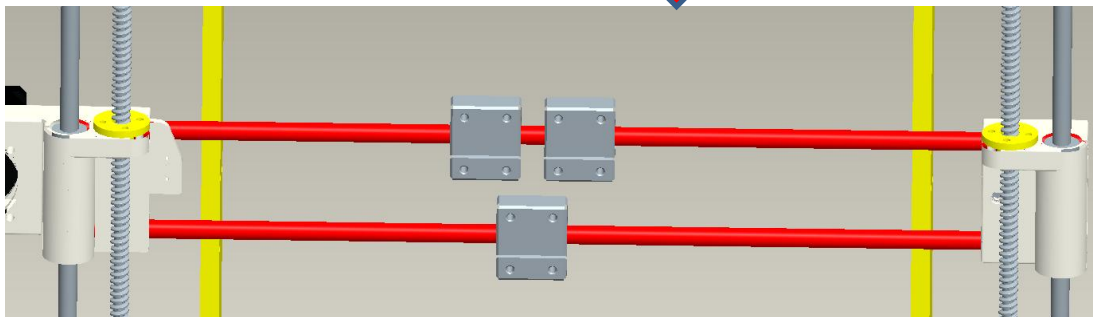

Name and Qty. of printer parts

Item	Name of parts	QTY.
1	Step 14	1
2	X axis Guide rod	2
3	Linear bearing	3

Assembly Step 16

Before disassembly

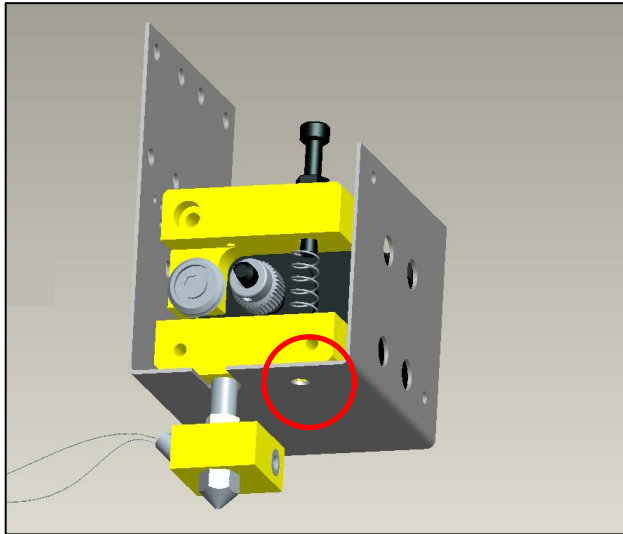

After disassembly

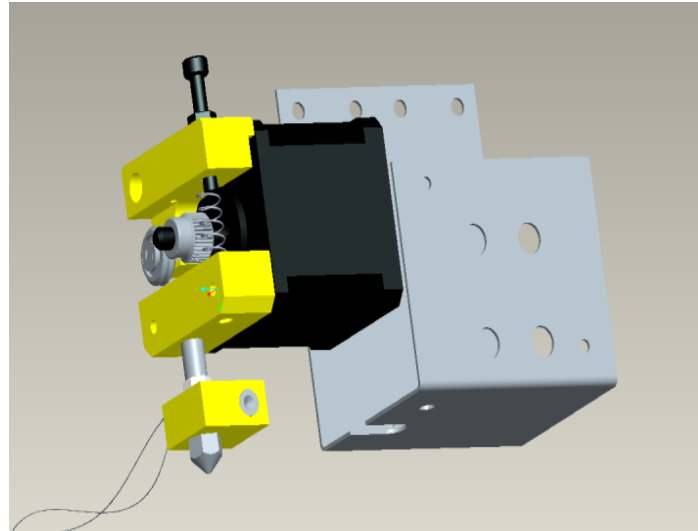

After disassembly

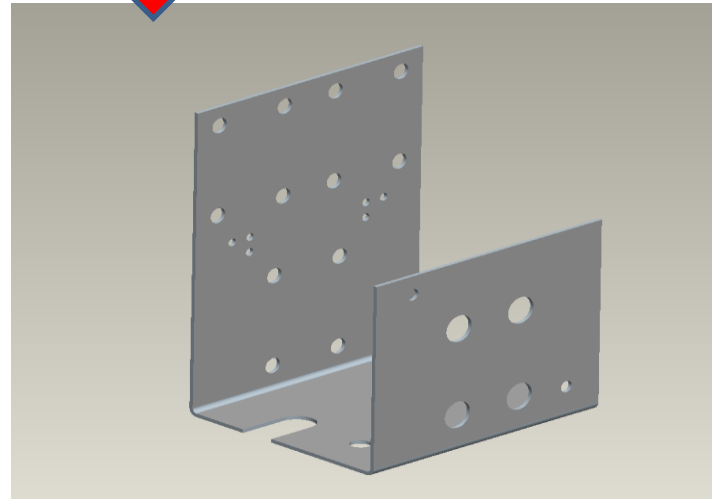

Loose M4*6 screws first,
then separate extruder
from L black aluminum
parts, remember to
keep the screws.

Assembly Step 17

Before Assembly

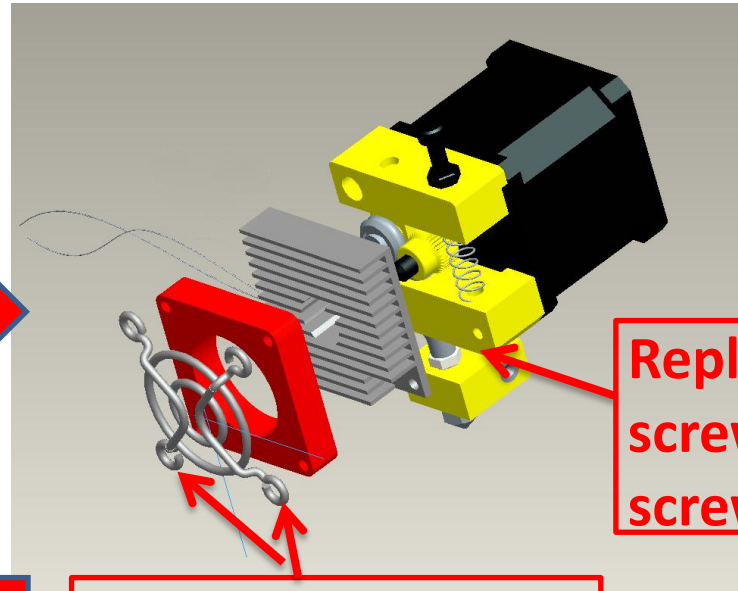

Replace M3*20 screws with M3*45 screws

After Assembly

M3*45 screw holes

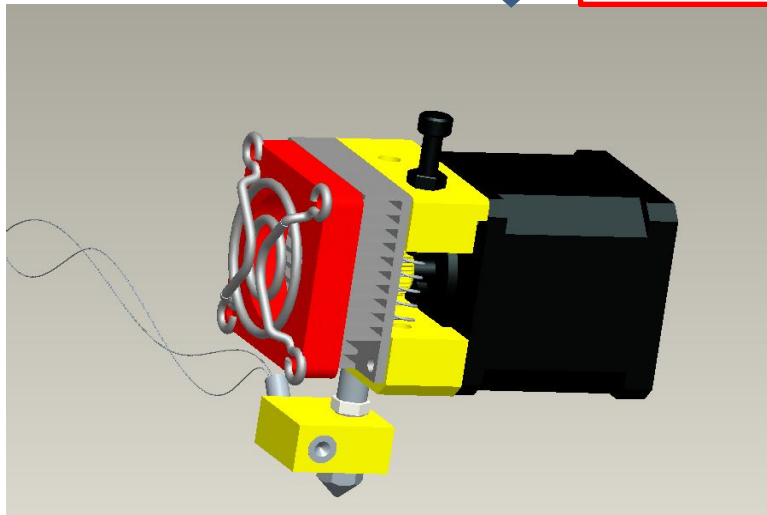

Name of QTY. of printer part

Item	Name of parts	QTY.
1	Extruder taken from Step 16	1
2	40*10 Fan	1
3	40*11 Cooling fin	1
4	Fan cover	1
5	M3*45 Screw	2
6	M3 Spacer	6-8

Assembly Step 18

Before Assembly

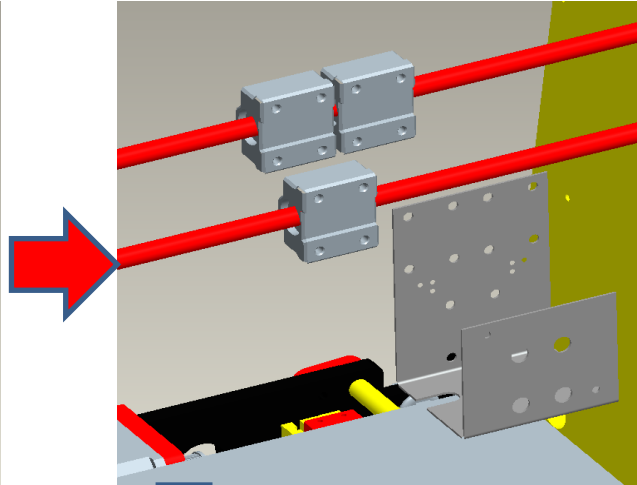
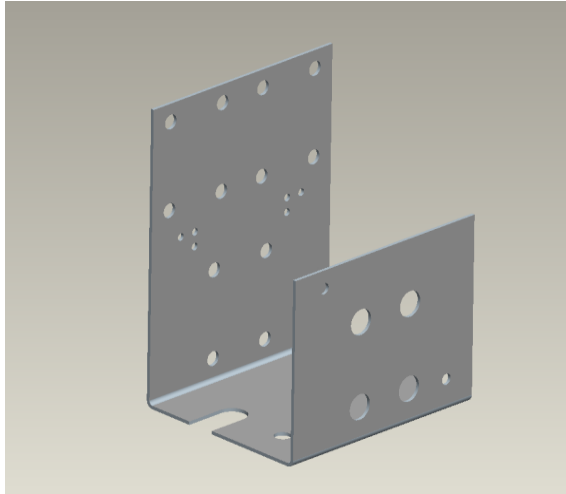

After Assembly

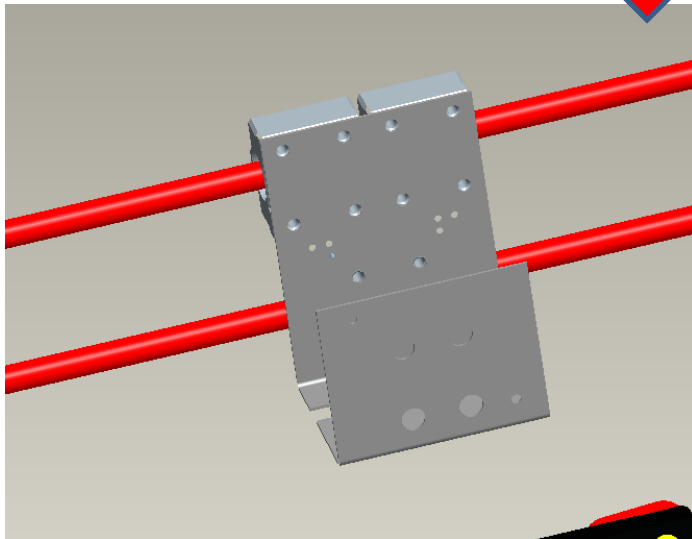

Name of QTY. of printer part

Item	Name of parts	QTY.
1	Step 15	1
2	Black Aluminum taken from Step 16	1
3	M4*8 Screw	12

Assembly Step 19

Attention: Install M4*6 screw. Tighten M6 Screw on the throat with spanner till extruder is not loose.

Name of QTY. of printer part

Item	Name of parts	QTY.
1	Step 17	1
2	Step 18	1
3	M4*6 We taken from Step 16	1

Before Assembly

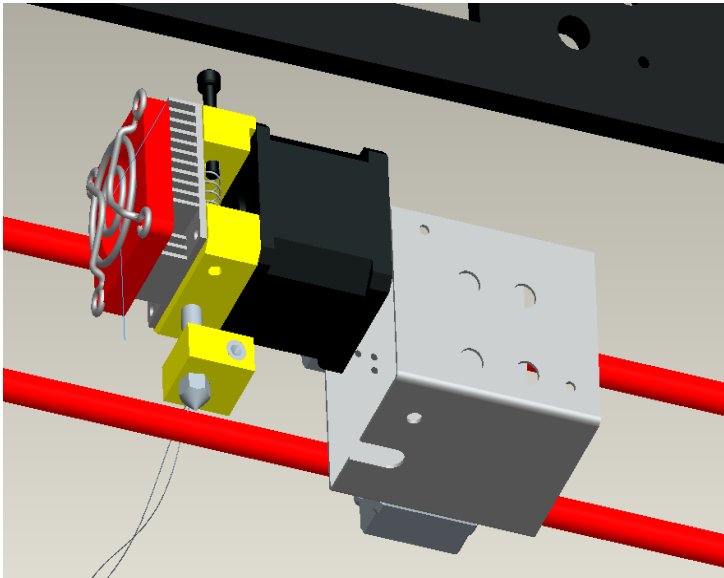

After Assembly

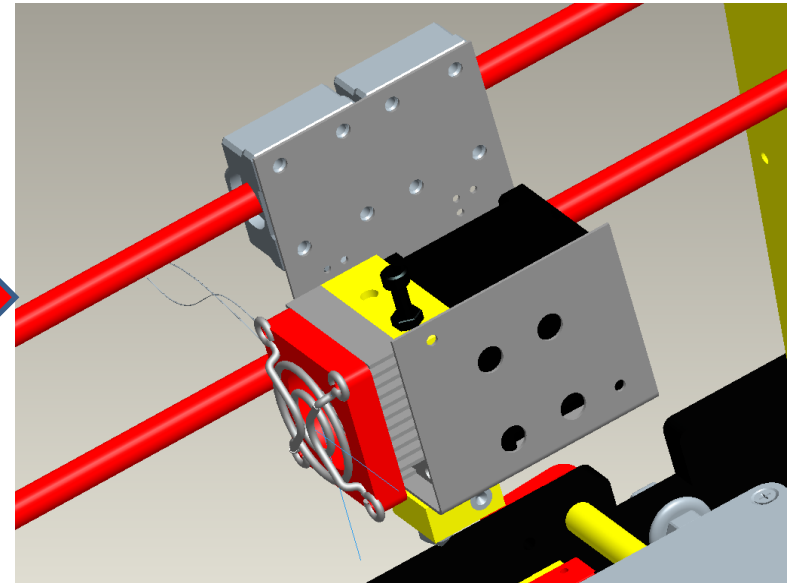

Assembly Step 20



Name of QTY. of printer part

Item	Name of parts	QTY.
1	Step 19	1
2	5015 Air blower	1
3	Wind mouth	1
4	M3*18 screw	2

Before Assembly

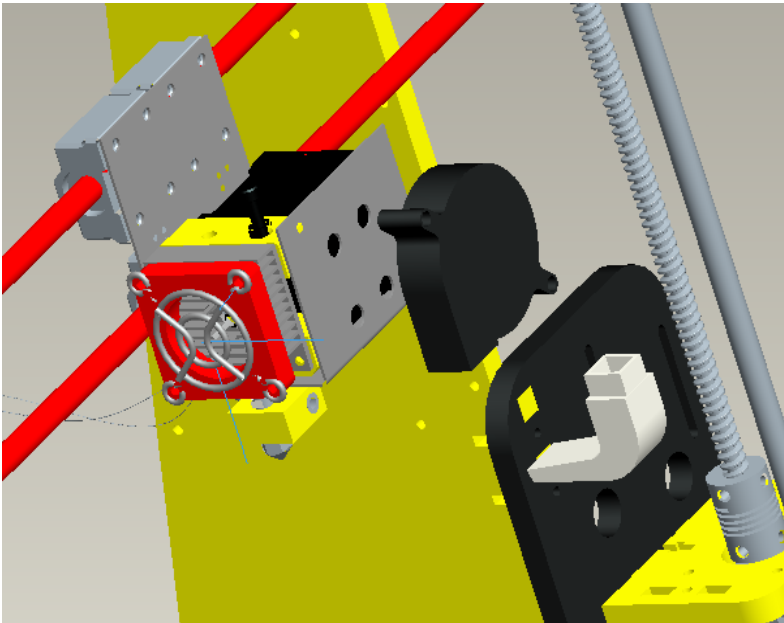

After Assembly

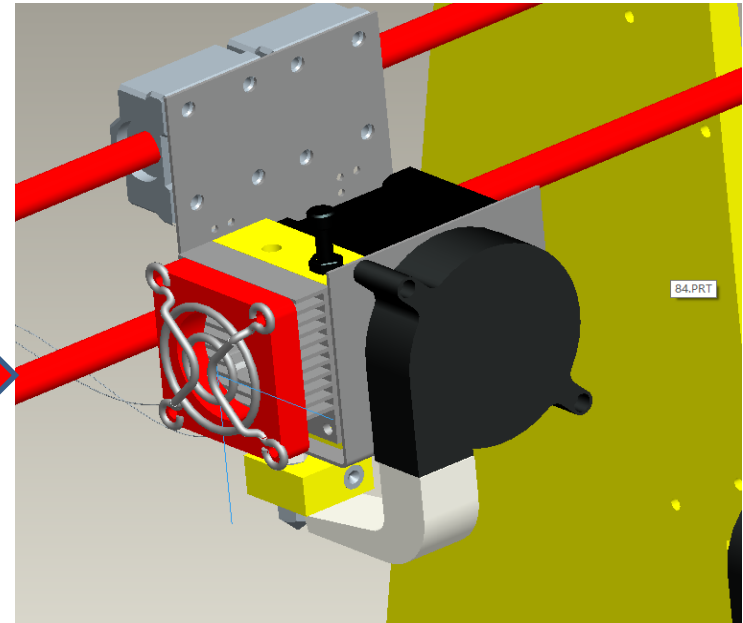

Assembly Step 21

Name of QTY. of printer part

Item	Name of parts	QTY.
1	Belt	1
2	M3*18 screw	2
3	M3 Nut 4	4

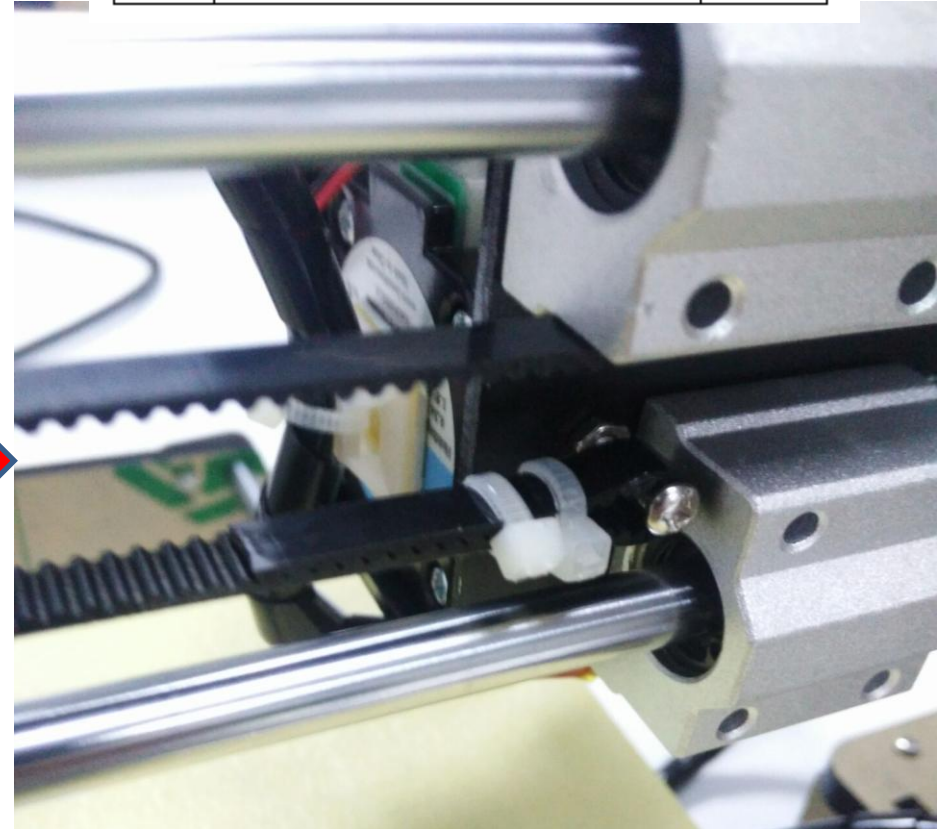

Attention: Belt is for X,Y axis transmitting . The length of belt is 1.5m in total. Normally there'll be 10-20cm left after installation.

Assembly Step 21

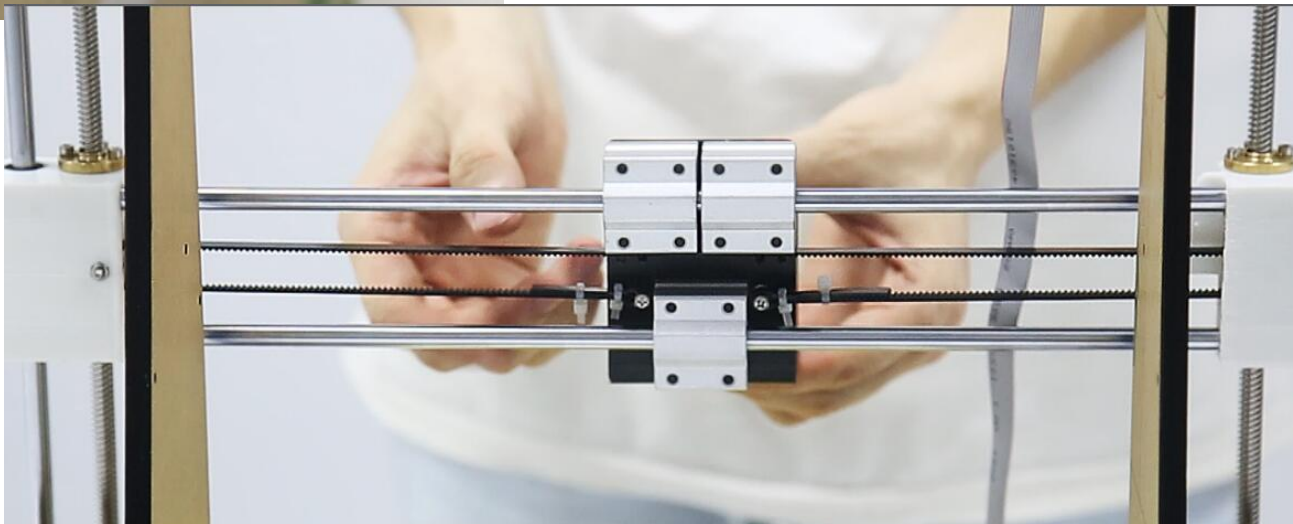
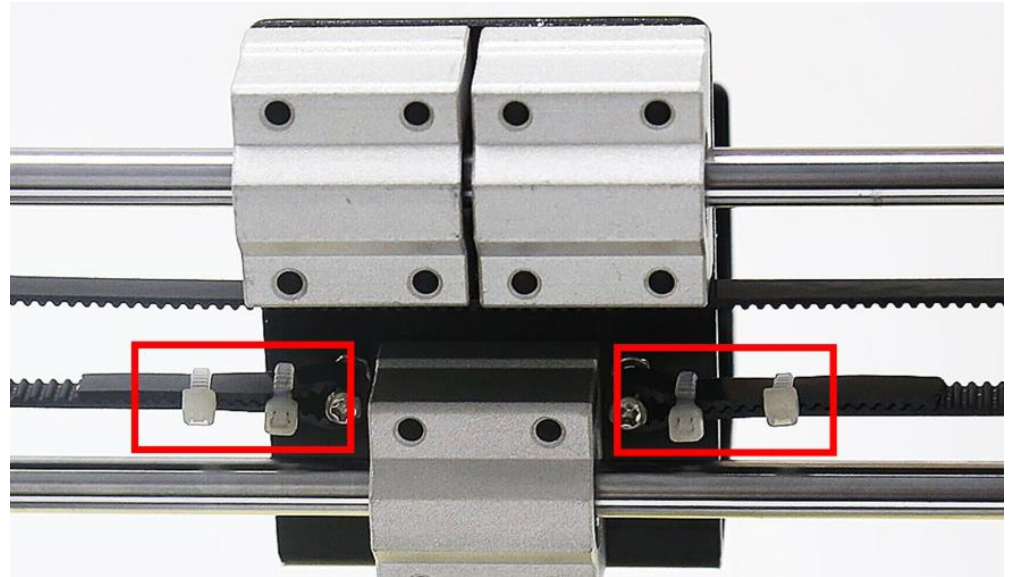
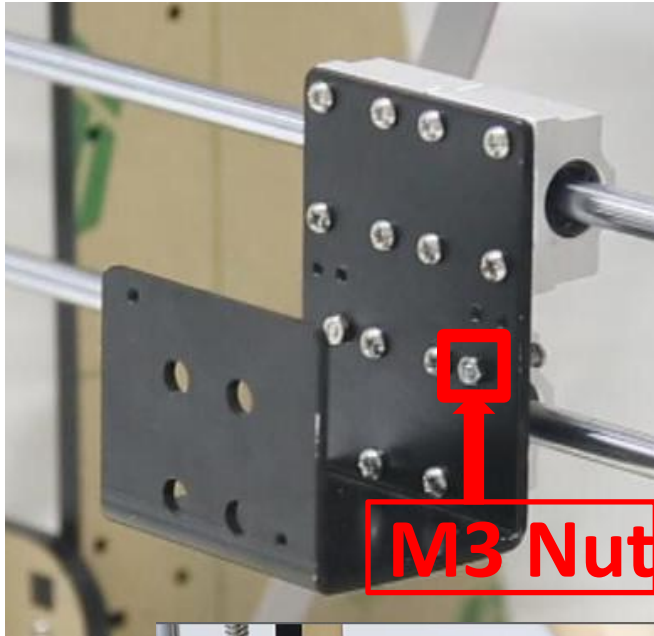

Assembly Step 22



Name of QTY. of printer part

Item	Name of parts	QTY.
1	LCD 2004 screen	1
2	Pillar washer M3*7	4
3	Screen baffle plate	1
4	M3*30 screw	4
5	M3 Nut	8

Before Assembly

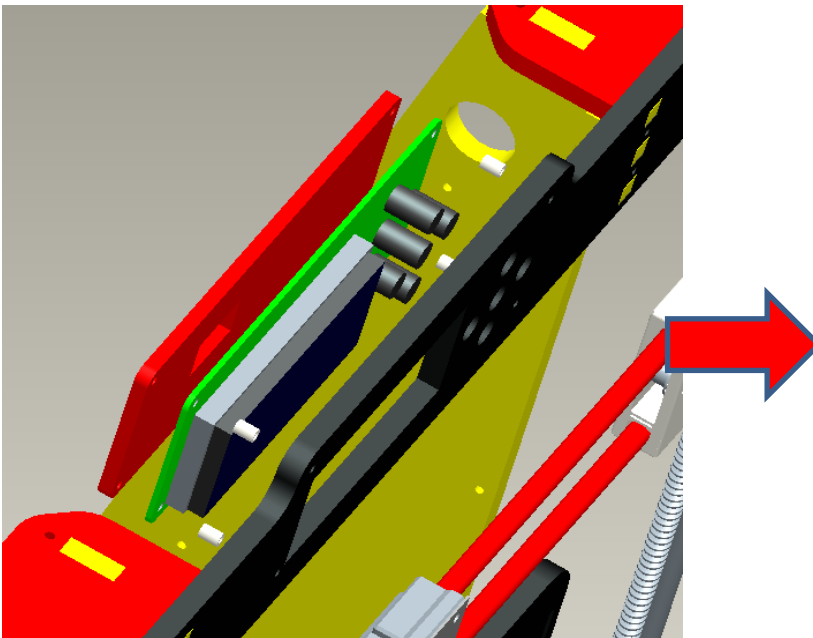

After Assembly

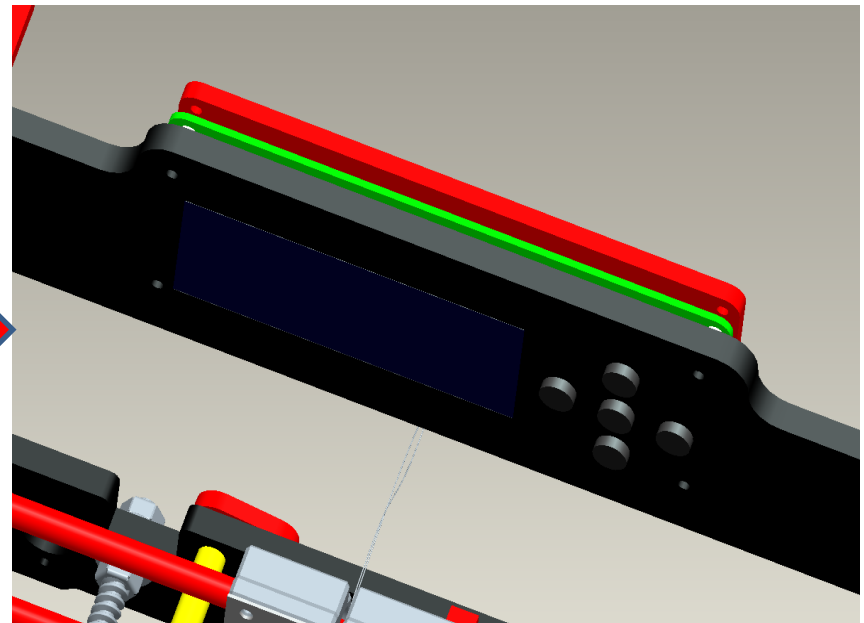

Assembly Step 23

Attention This is the wiring diagram of power supply. 1, 2, 3 separately represent the line of fire (brown), Zero line (blue), ground wire (yellow). 4, 5, 6 represent negative pole (black) (-); 7, 8, 9 represent the positive pole (red) (+). To avoid danger, please assure the installation is correct.

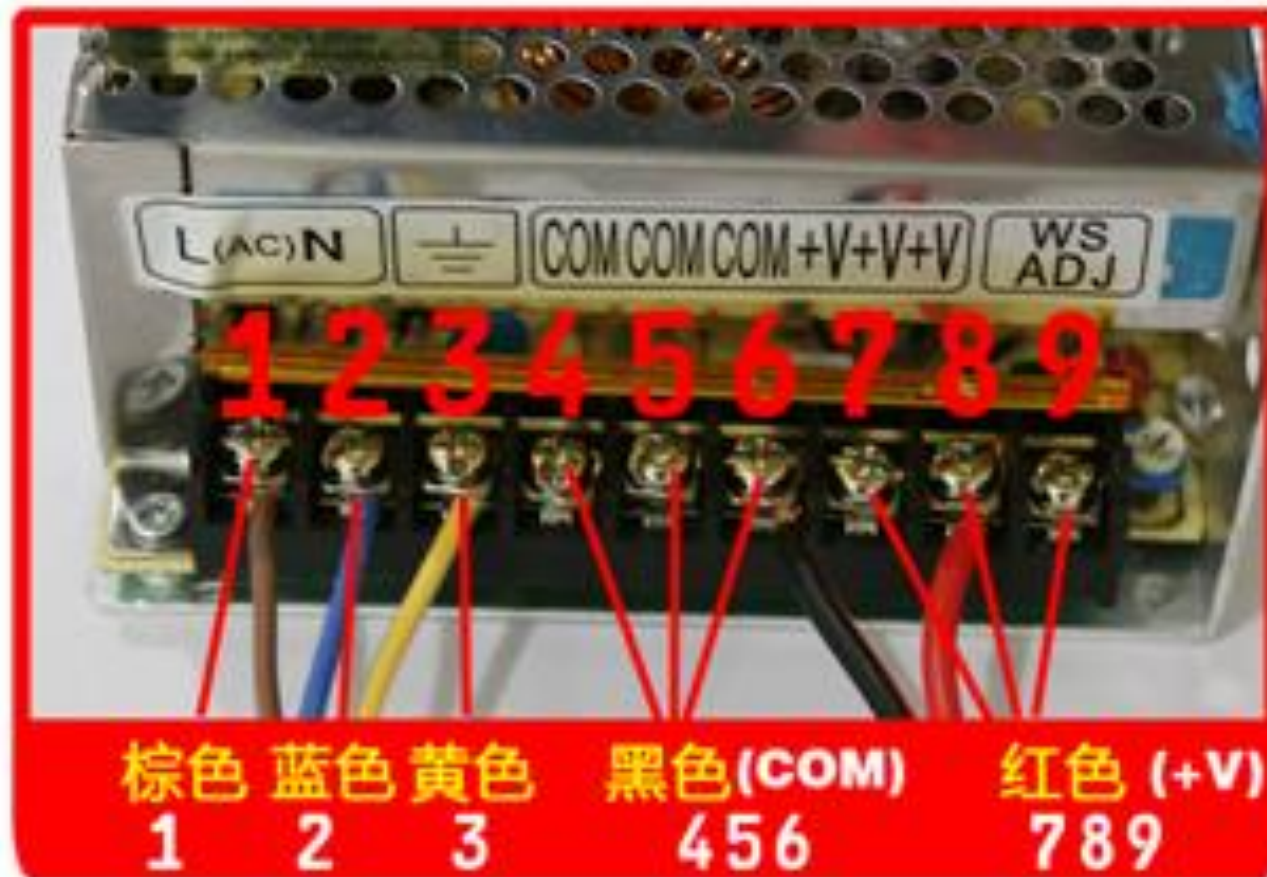

Assembly Step 24

Red circles stand for the power screw holes



Name of QTY. of printer part

Item	Name of parts	QTY.
1	Step 22	1
2	Power Supply 12V	1
3	M3*12screw	3

Before Assembly

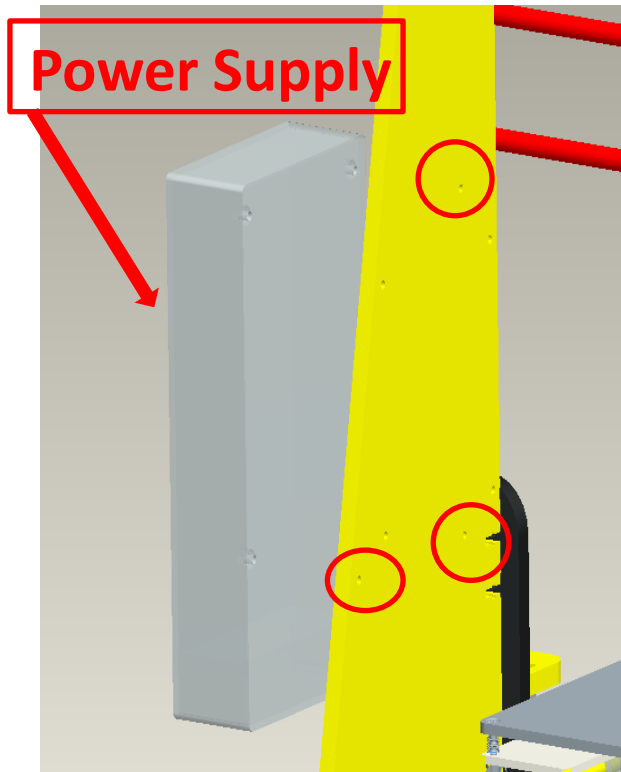

After Assembly

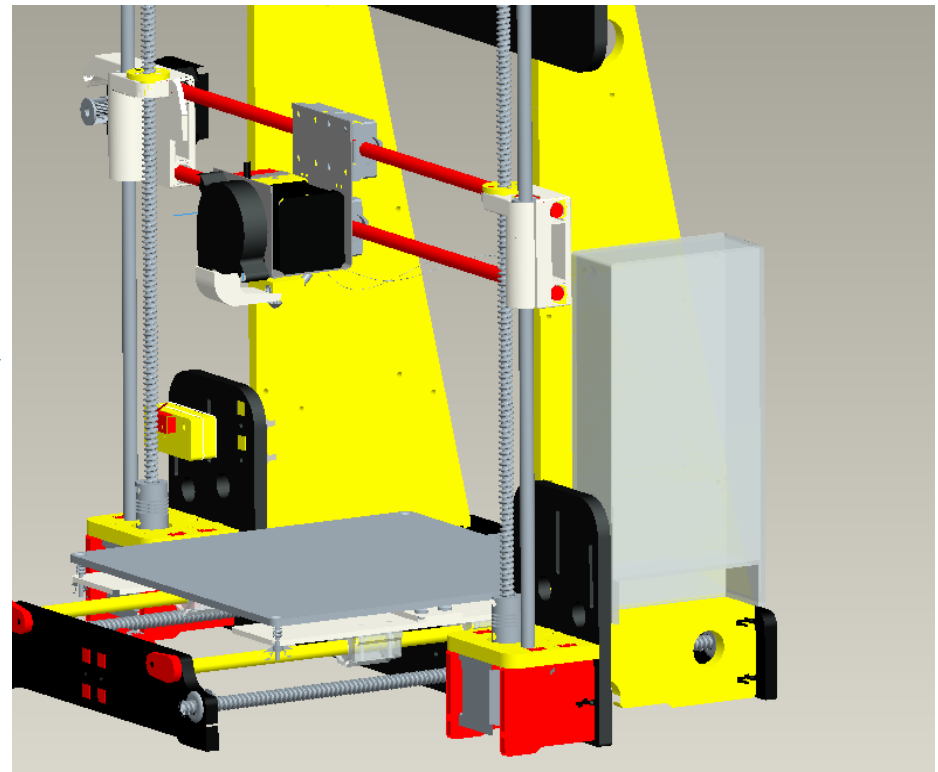

Assembly Step 25

Before Assembly

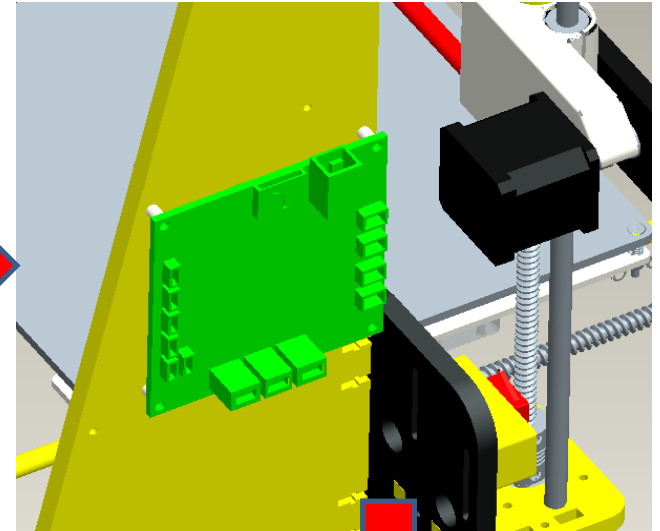
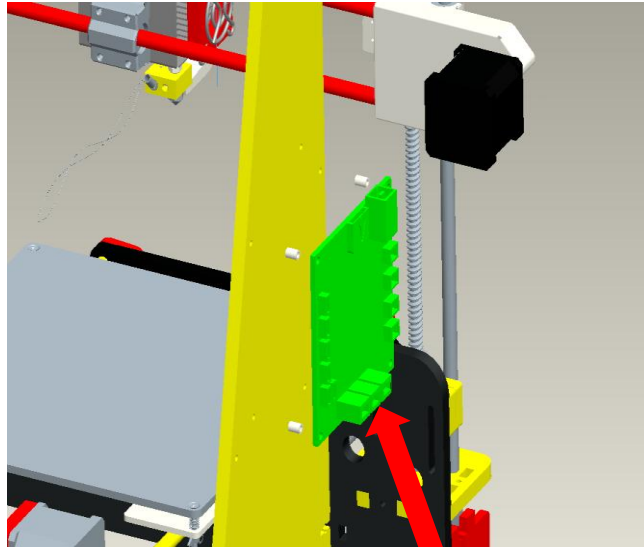

Mainboard

After Assembly

Name of QTY. of printer part

Item	Name of parts	QTY.
1	Step 23	1
2	Mainboard	1
3	M3*30 screw	4
4	M3 Nut	4
5	Pillar washer M3*15	4

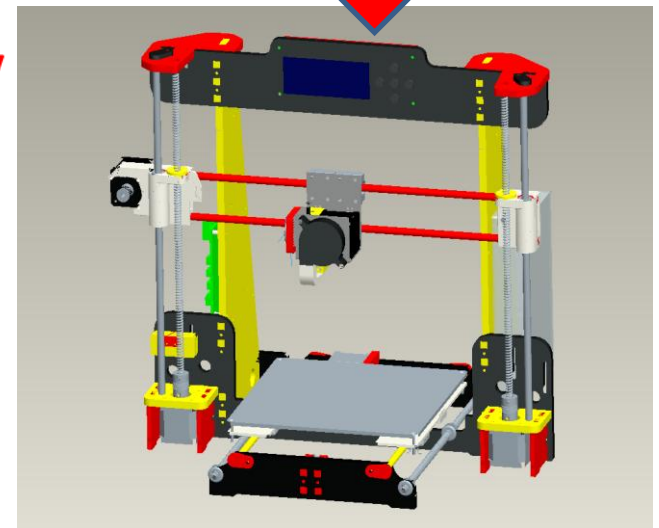

Assembly Step 25

Attention: Please use the corresponding wire , especially motor wire & limited switch wire.

Length of A8 Components Wire

NO.	Option	Length(mm)
1	Power supply wire	700mm
2	X motor wire	400mm
3	Y motor wire	400mm
4	Left Z motor wire	400mm
5	Right Z motor wire	900mm
6	X limited switch wire	550mm
7	Y limited switch wire	700mm
8	Z limited switch wire	200mm
9	Extruder motor wire	900mm
10	4010 Fan wire	1100mm
11	5015 Blower wire	1100mm
12	Heating pipe wire	1000mm
13	Extruder thermistor wire	1000mm
14	Hotbed wire	900mm
15	X Belt	1500mm
16	Y Belt	
17	Screen wire	500mm

Assembly Step 25

Attention: Please connect the electronics wire to each components correspondingly.

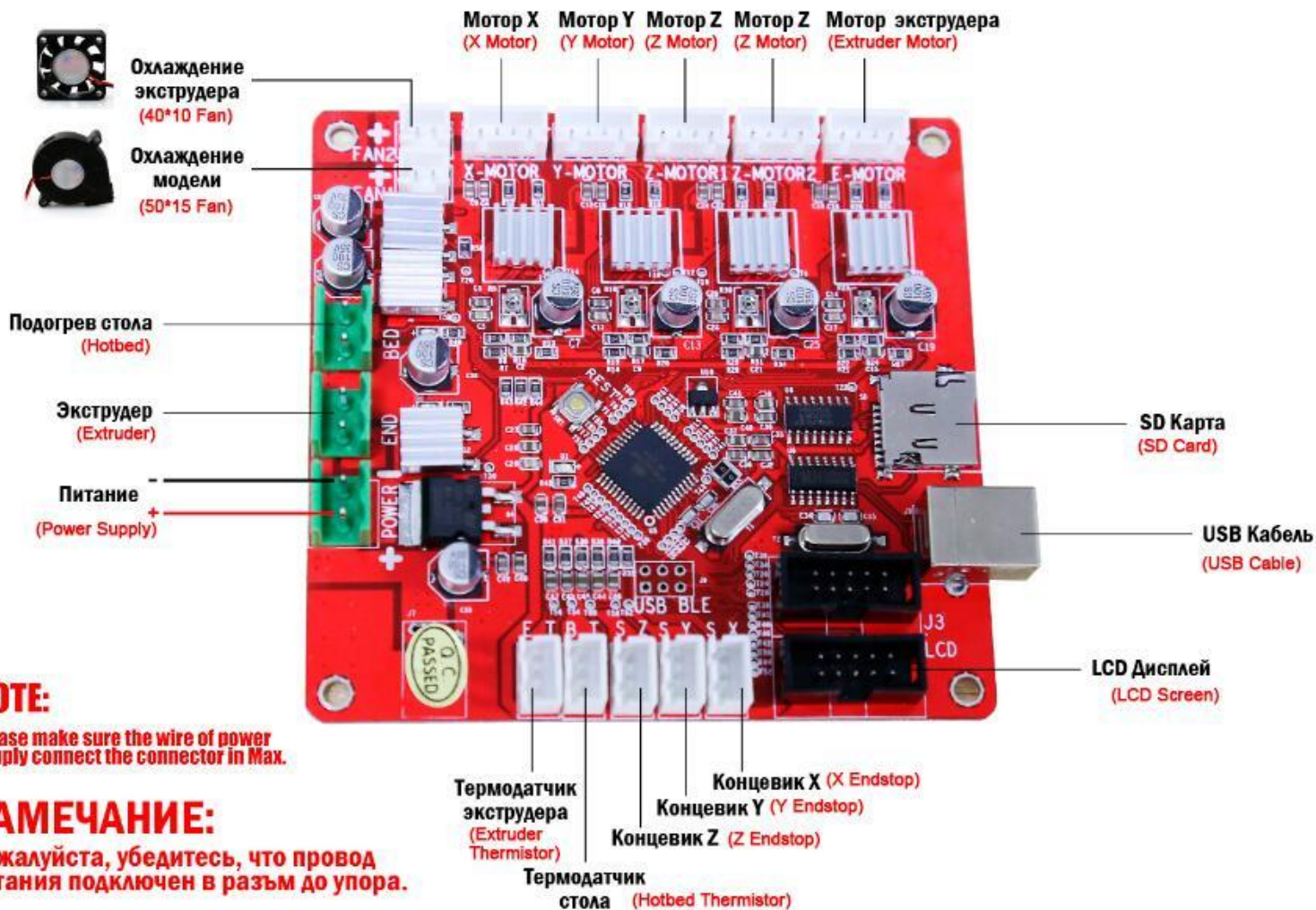

Assembly Step 26



Name of QTY. of printer part

Item	Name of parts	QTY.
1	Filament support plate	2
2	Filament support plate connecting plate	2
3	Threaded rod 150mm	1
4	M8 screw	4
5	M3*18 screw	4
6	M3 Nut	4

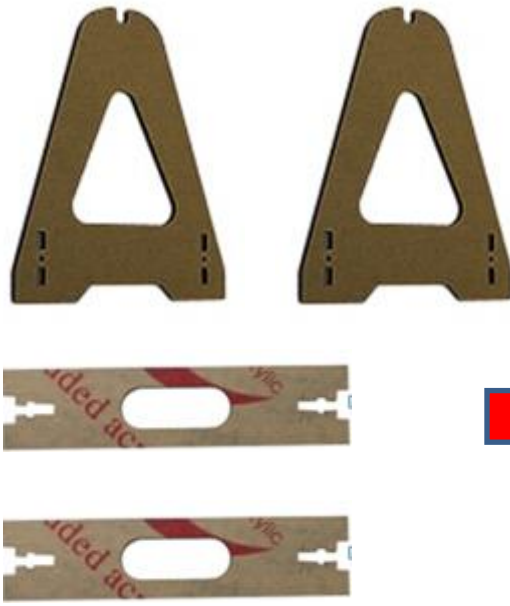

Assembly Step 27 Installation Picture 1

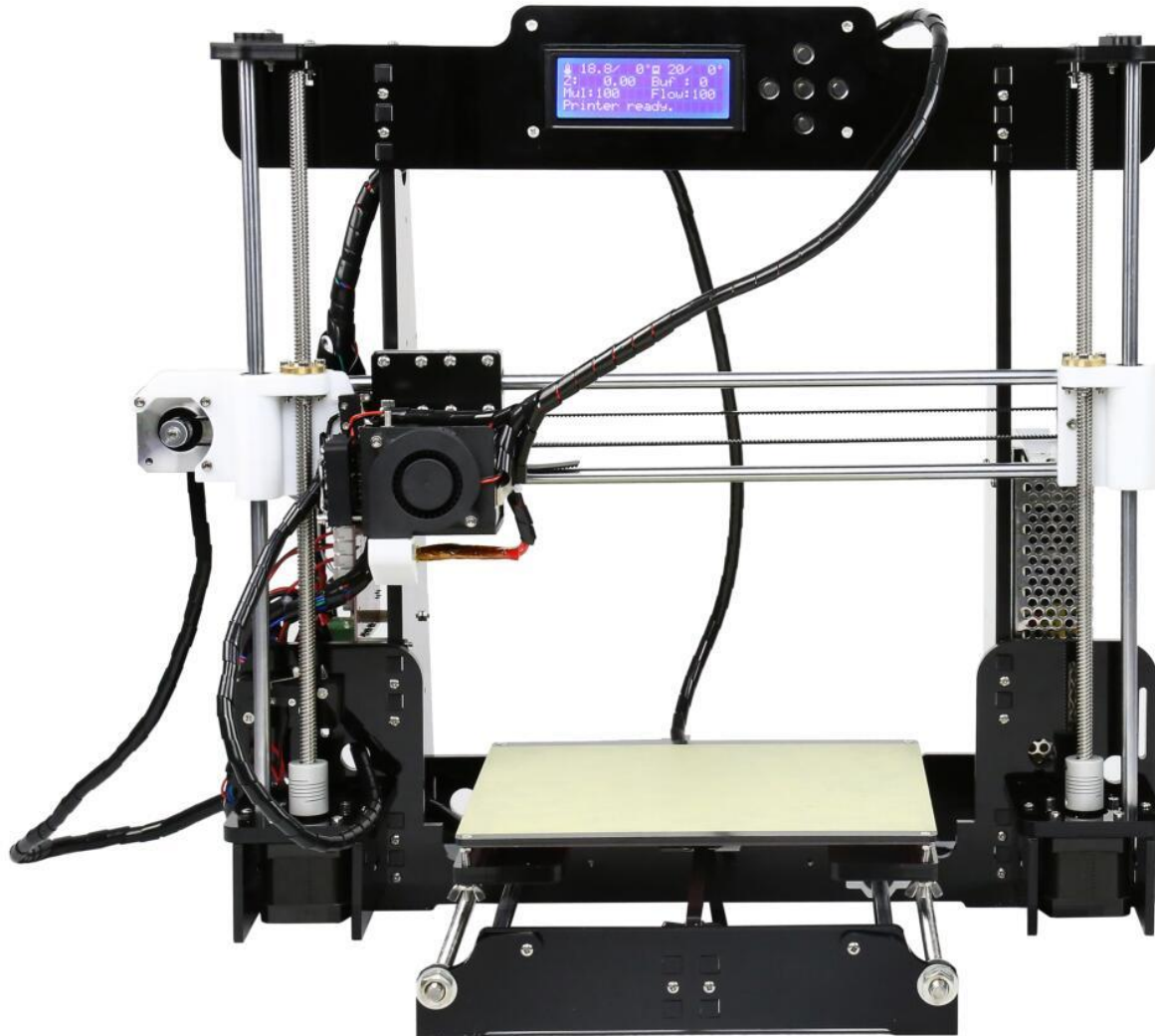

Assembly Step 27 Installation Picture 2

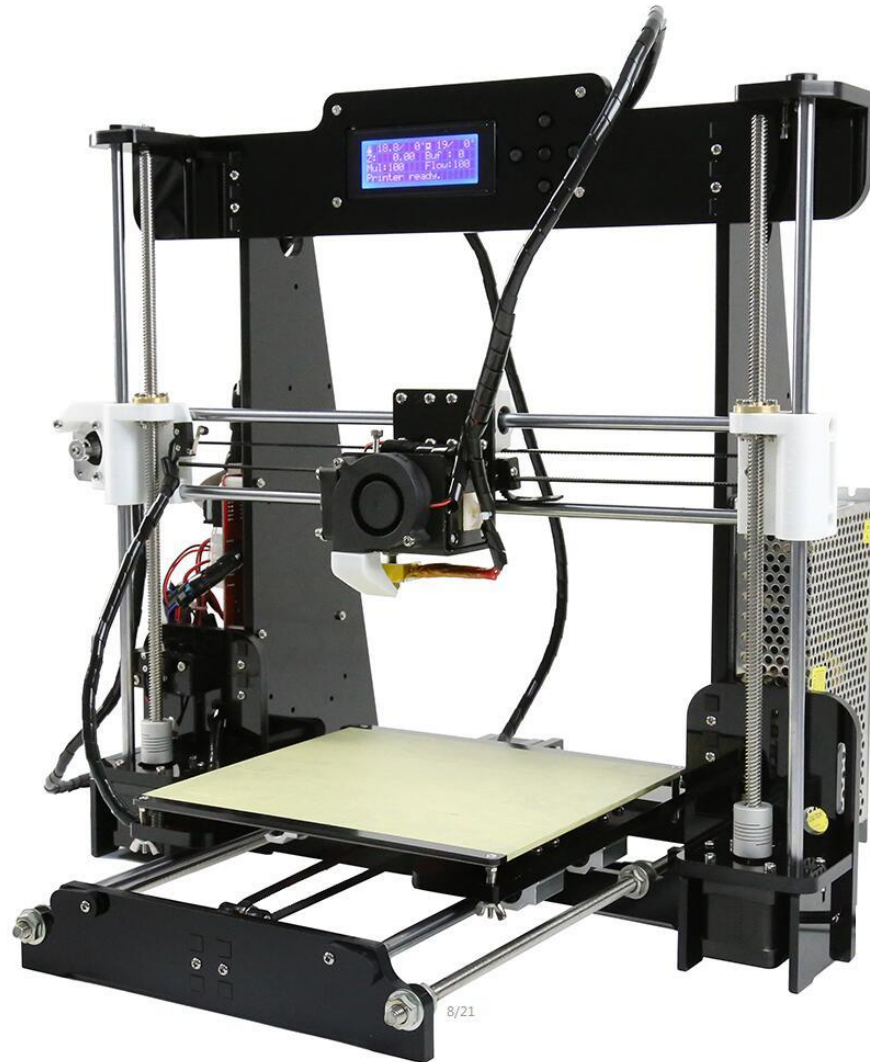

Assembly Step 27 Installation Picture 3

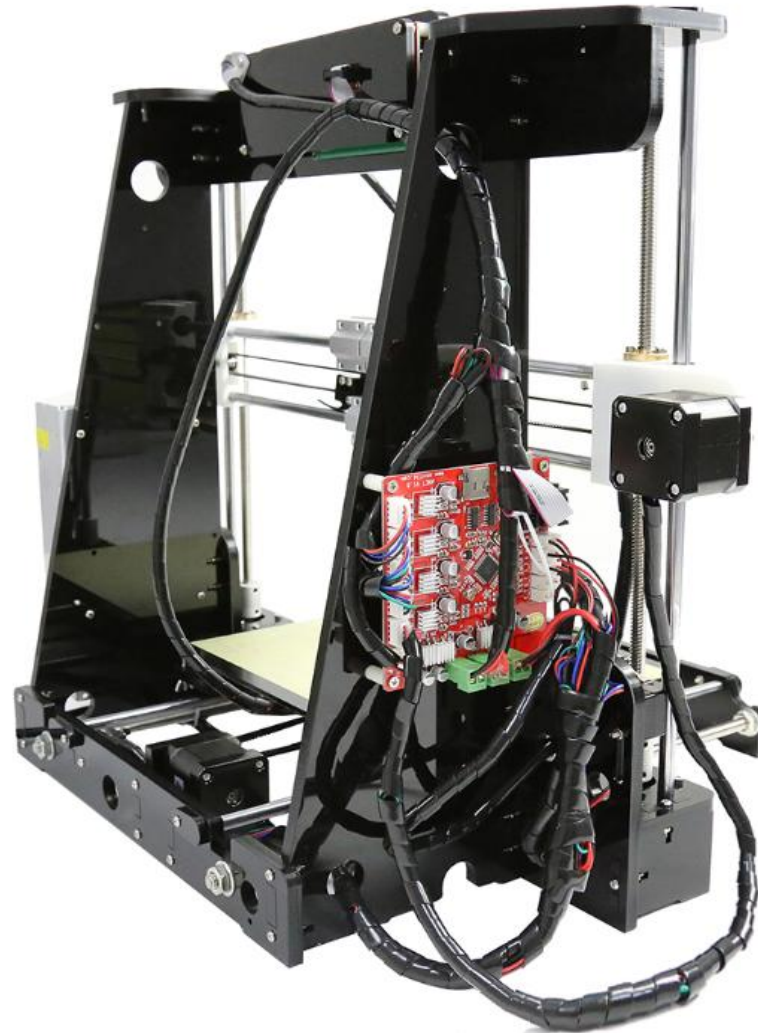

Assembly Step 27 Installation Picture 4

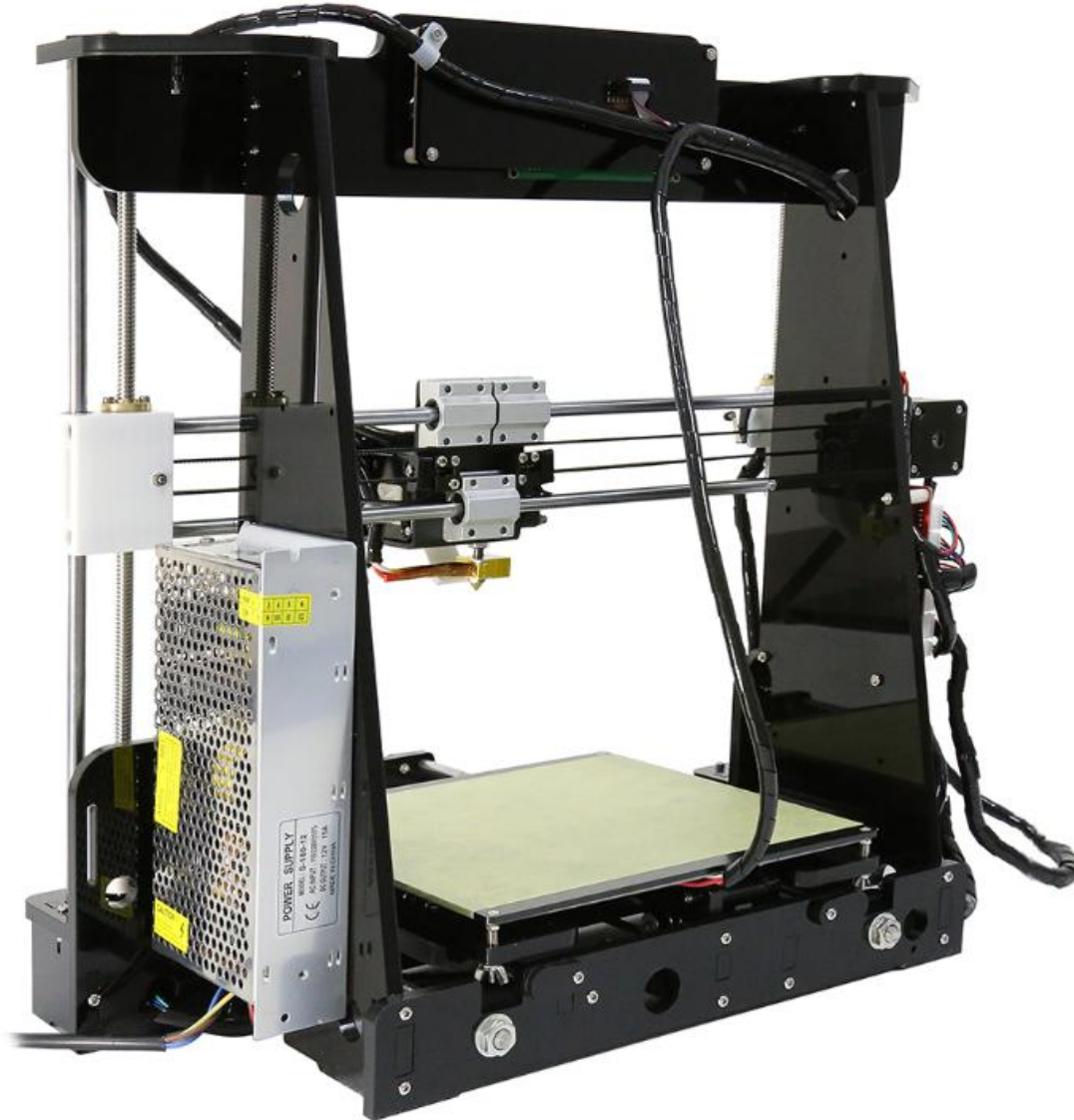

Assembly Step 27 Installation Picture 5

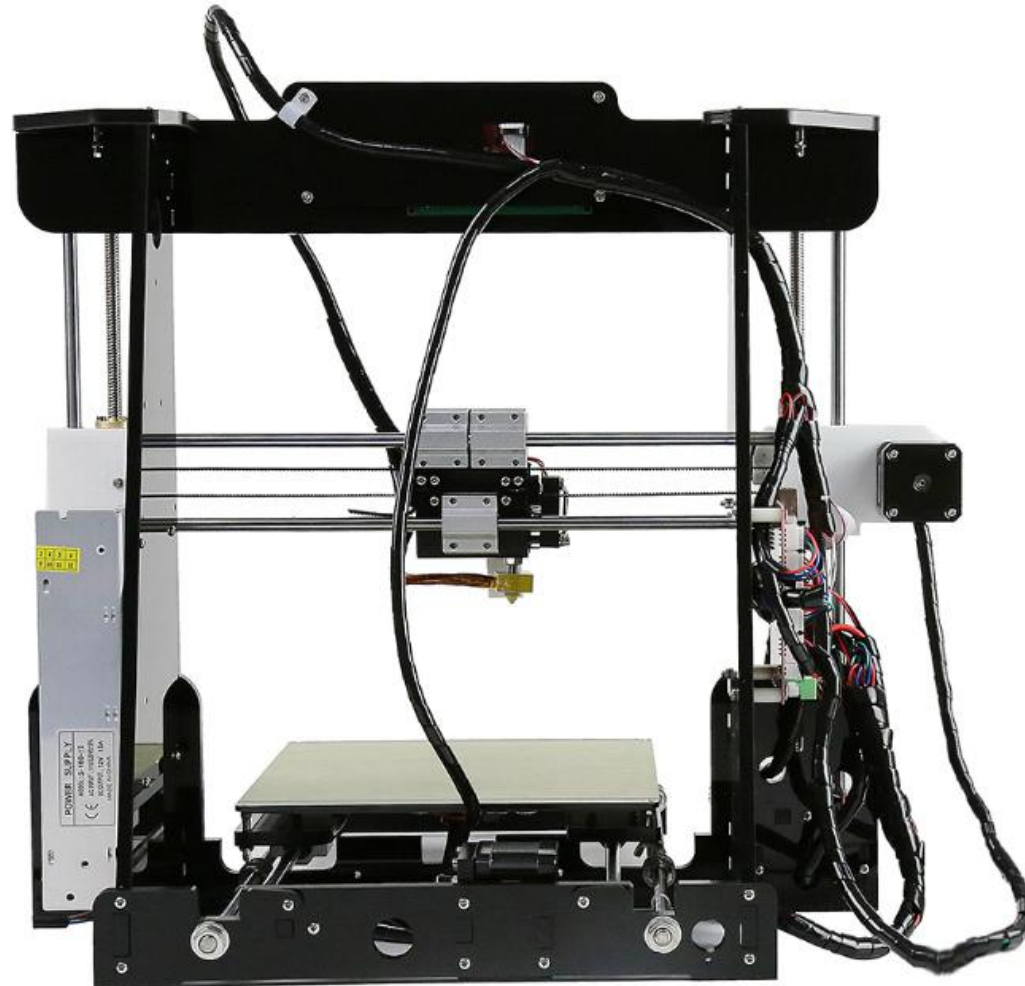

Installation Complete

- **Congratulations ! You have just made yourself a 3D printer !**
- **Please contact your 3D printer supplier if any puzzles during using process.**
- **Thank you for choosing our products, we will always provide you more services.**