

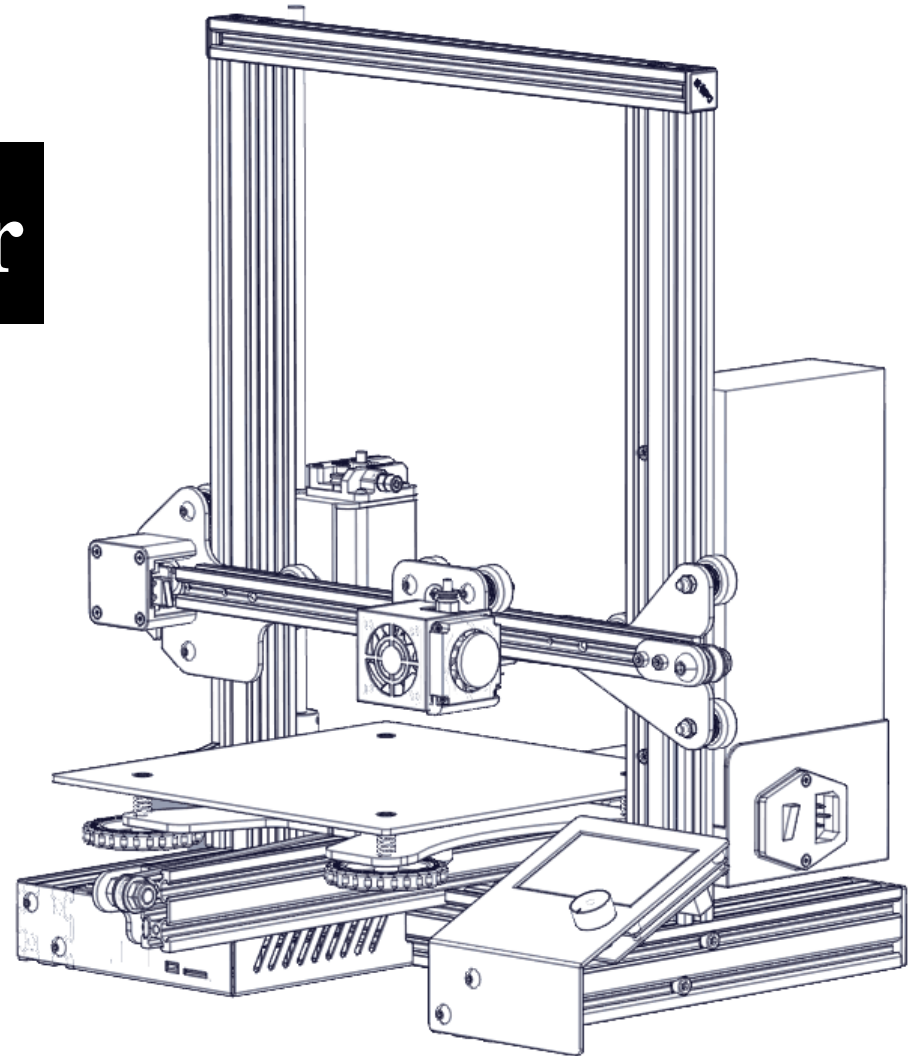

Ender-3 3D Printer

Instructions for assembly

- ◆ This guide is for the Ender-3 3D printer.
- ◆ Select the correct input voltage to match your local mains (220V or 110V).
- ◆ Because of software/hardware upgrades and model differences, new revisions may not be listed in this guide.
- ◆ Detailed instructions for use are available on the SD card.



Step1. BOM

List 1

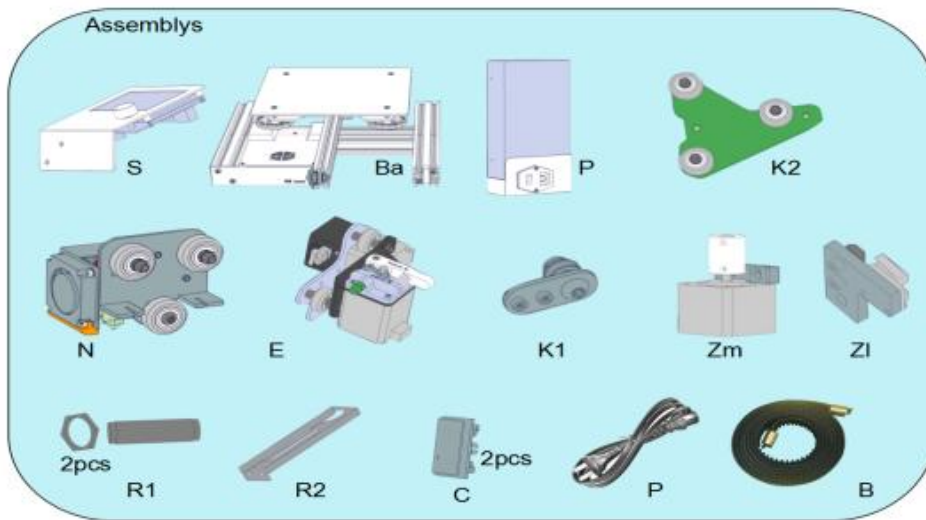

List 2

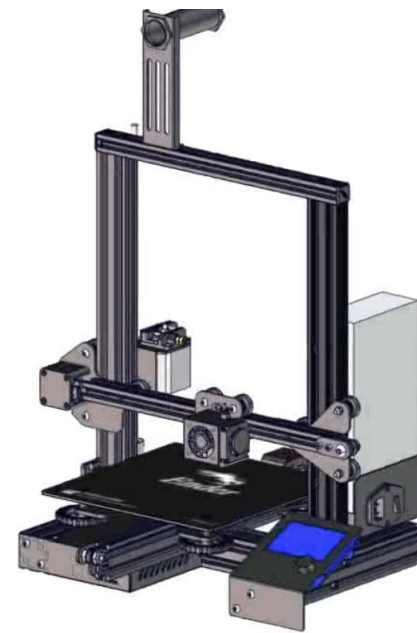
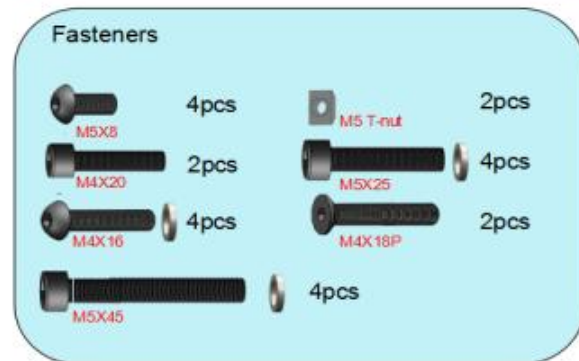
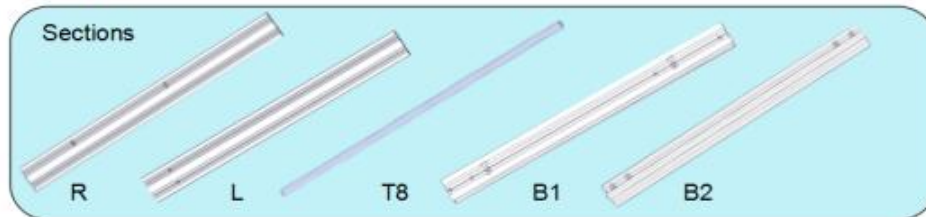

a. Remove the parts from the box and remove any tape and padding from the parts. Inspect the parts to make sure they were not damaged in shipment.

b. Check the items on List 1 and List 2. The wiring harness of component (Ba) and component (N) has already been connected.

Step 2. Install aluminum extrusions (L) and (R) to base (Ba)

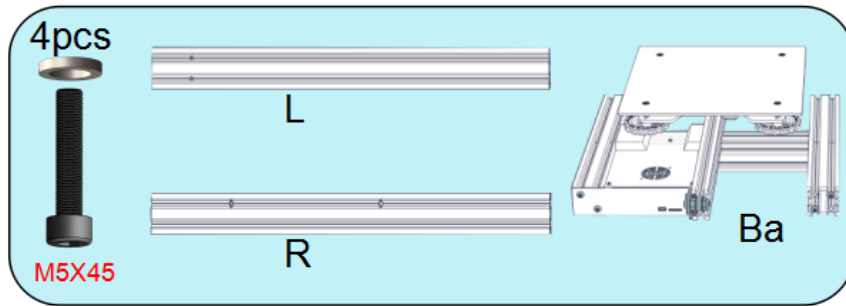

Prepare the following parts:

- a. M5x45 socket head hex screws (4x)
- b. M5 washer (4x)
- c. Aluminum profiles (L) (1x)
- d. Aluminum profiles(R) (1x)
- e. Base (Ba) (1x)
- f. 4mm Allen key

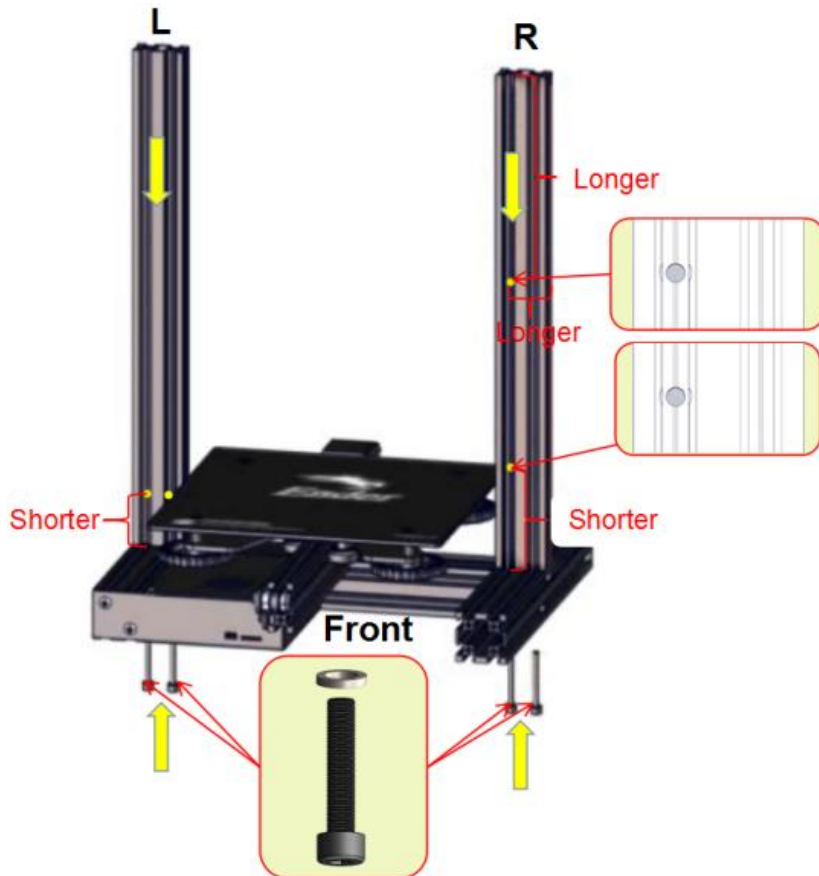

Step 1. Place (L) on the left and keep the direction of the base (Ba) facing front;

Step 2. Place the aluminum profile (L) vertically over the left side frame of the base (Ba), be careful that the (L) profile has the threaded holes with the short sides facing downwards. Using the M5x45 screws and washers, pass through bottom hole of the aluminum profile at the left side of the base (Ba), align the threaded hole at the bottom of the aluminum profile (L), and tighten the screw with an hexagon wrench;

Step 3. Place the aluminum profile (R) vertically over the right side frame of the base (Ba). Note that the (L) profile has through holes with the short sides facing downwards. Also note that the holes are to the left (see diagram) to ensure that the aluminum profiles are oriented correctly. , Using M5x45 screws and washers, pass them through bottom hole of the aluminum profile at the right side of the base (Ba), align the threaded hole at the bottom of the aluminum profile (R), and tighten with the 4mm Allen key.

Step 3. Power supply and operation screen installation

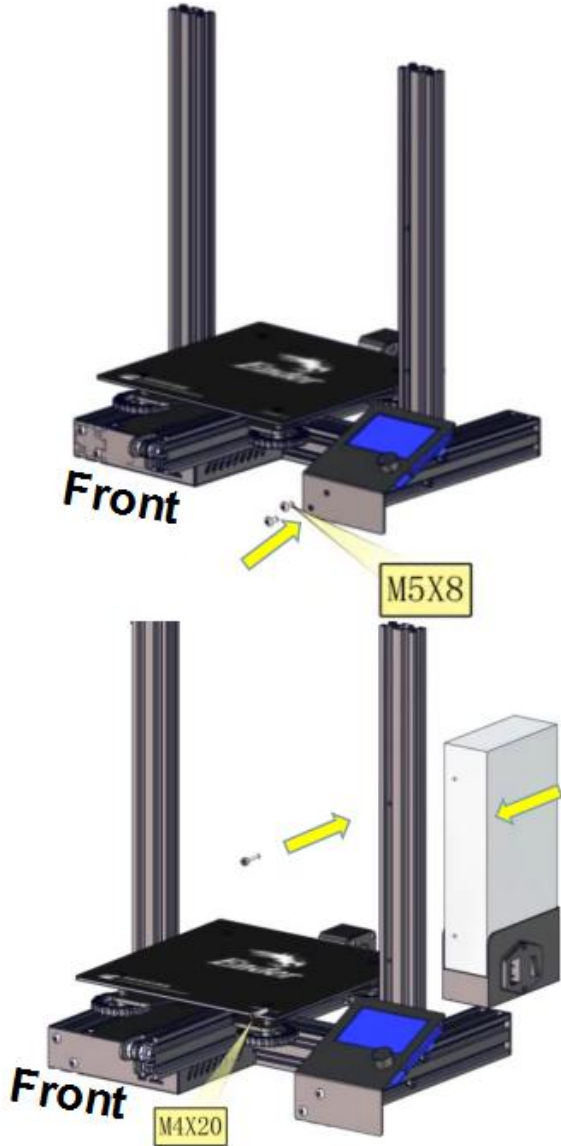

2pcs
M5X8

S

2pcs
M4X20

P

Prepare the following parts:

- M5x8 hex drive rounded head screws (2x)
- Operation screen assembly(S) (1x)
- M4x20 socket head hex screws (2x)
- Switching power supply assembly (P) - (1x)
- 3mm Allen key
- *Select the correct input voltage to match your local mains (220V or 110V).**

Step 1. Keep the the base (Ba) facing towards you.

Step 2. Align the hole at the bottom left of the operation screen with the threaded hole of the aluminum profile on the right side of the base (Ba), secure with M5x8 screws, and use the Allen key to tighten them.

Step 3. Attach the switching power supply unit to the bottom as show on the diagram to the left (button switch at the bottom right). Screw holes of the switching power supply should pass through the holes of the aluminum profile (R). Using M4x20 screws, pass through the front of the profile (R) and use the Allen key to tighten the screws.

Step 4. Z axis limit switch installation

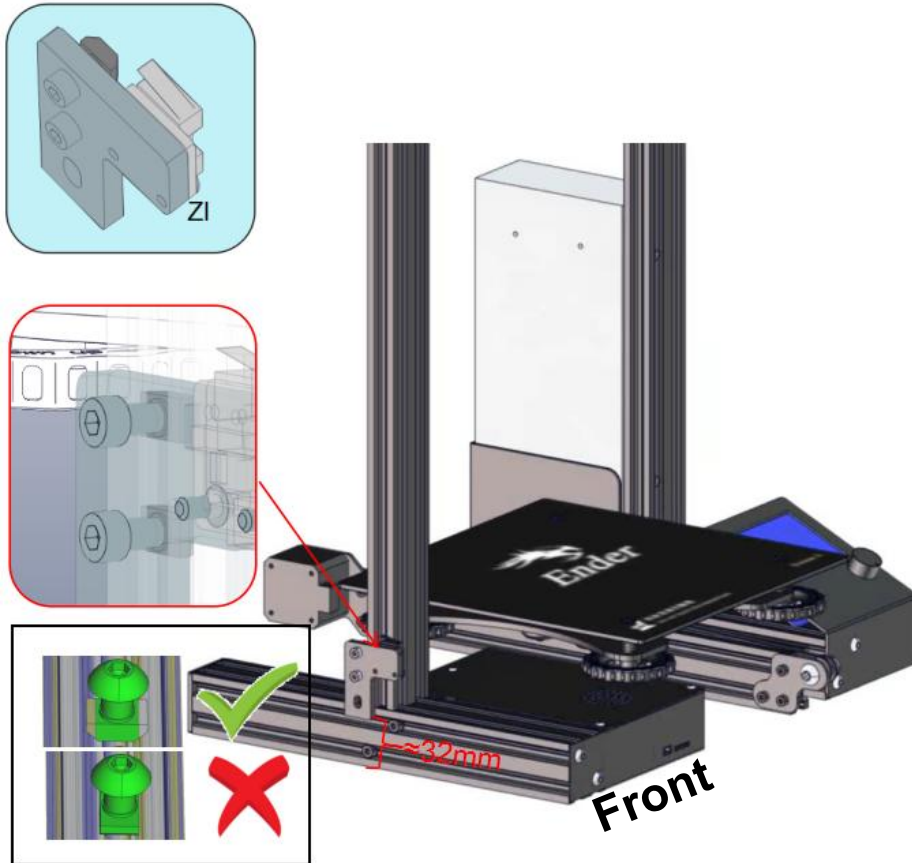

1. Prepare limit switch assembly (ZI) and 3mm Allen key;

2. The direction of the base (Ba) stays at the front, and the switch assembly (ZI) is mounted on the left side of the base (Ba) (as shown in the diagram on the);

3. Loosen the T-nut by hand until it is at the end of the threads, but not so far it might fall off. Then, fit into the slot in the aluminum profile. When the bolt is tightened, the nut rotates 90 degrees and then grasps the inside of the slot.

4. Align the T-nut with the bottom aluminum profile groove and secure with the Allen key

5. The limit switch assembly (ZI) has a small hook that attaches to the aluminum profile underneath the base (Ba) (reference: about 32 mm from the bottom).

Step 5. Z axis motor assembly installation

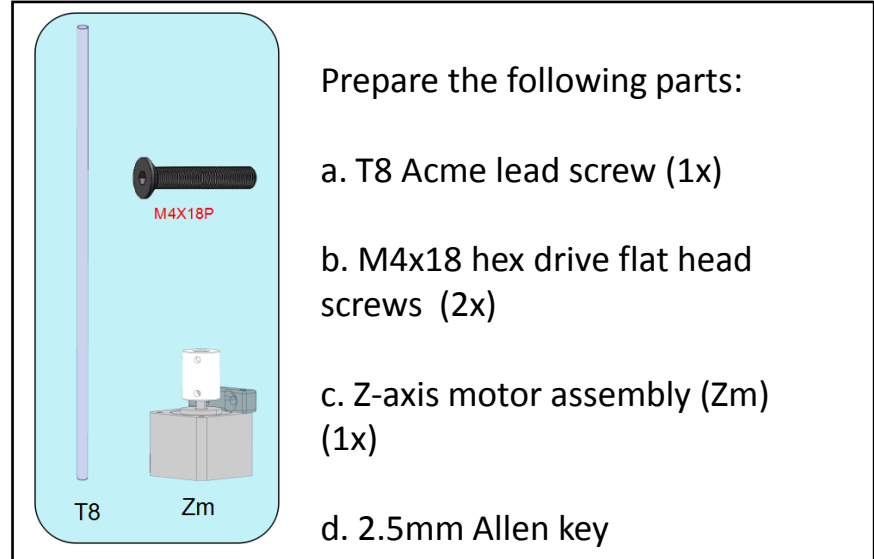
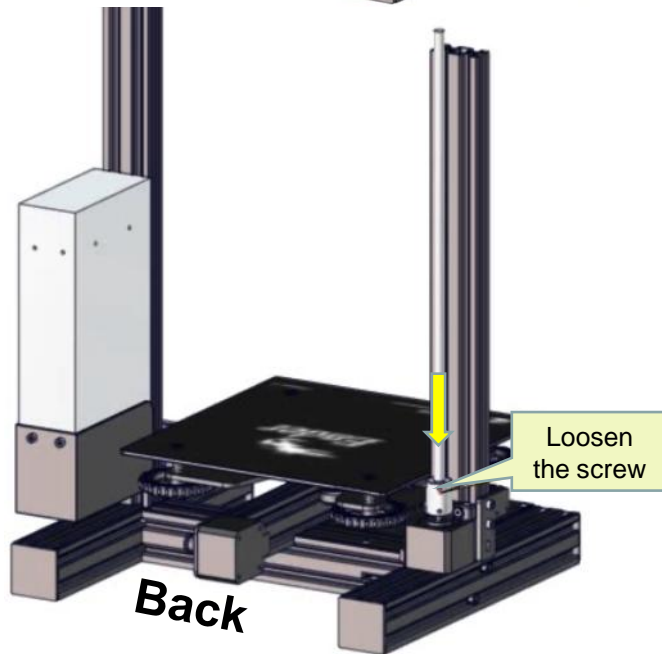
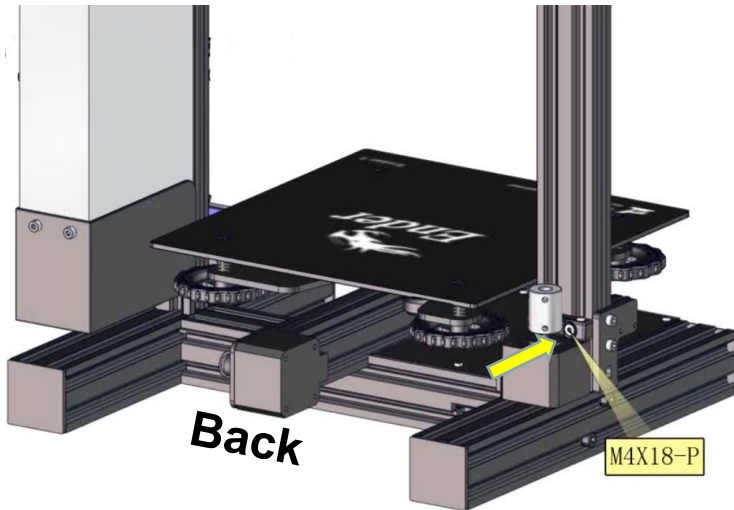

Step 1. Rotate base (Ba) 180° until the back is facing towards you.

Step 2. Position the hole of Z-axis motor assembly at the threaded hole of the aluminum profile (L) in the base (Ba), secure with M4*18 screws, and tighten the screws with a 2.5mm Hexagon wrench.

Step 3. Use a 2.5mm Hexagon wrench to loosen the screws of the Z-axis coupling to prepare for insertion of the lead screw.

Step 4. Insert the T8 lead screw into the coupling, and tighten the screw that was loosened in the previous

Step 6. X-axis bearing installation preparation

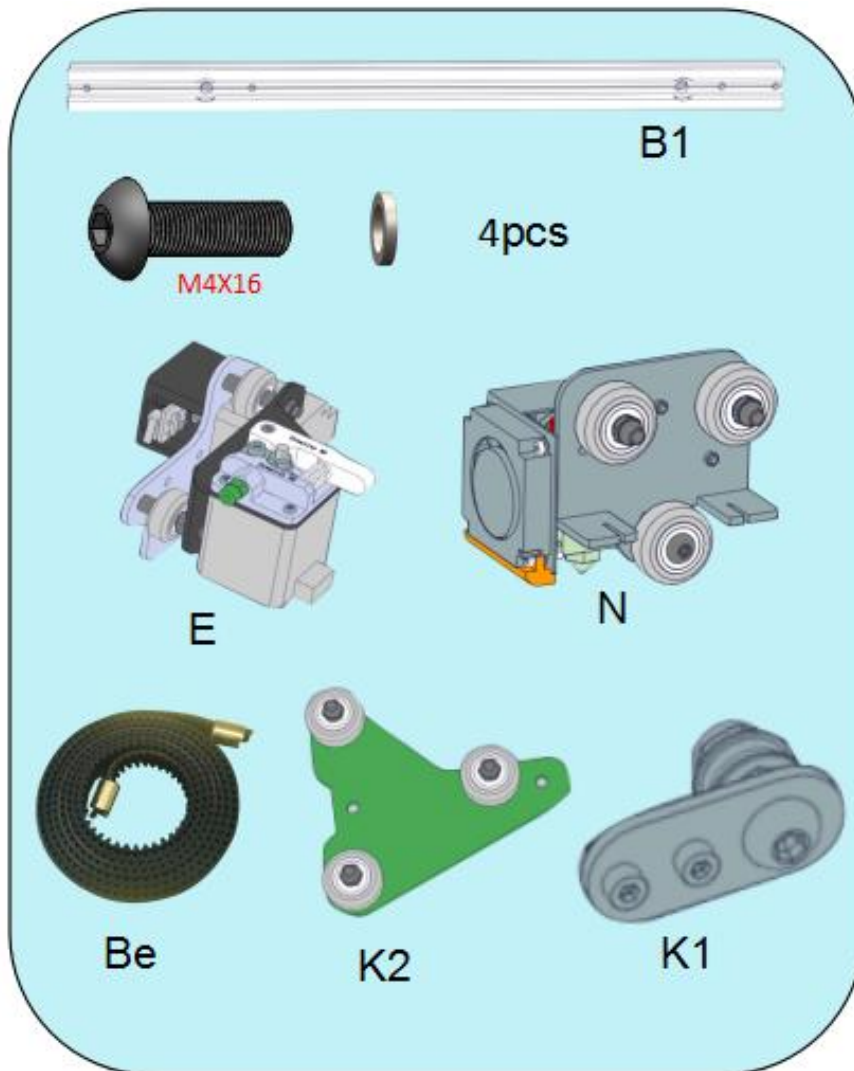

Prepare the following parts:

- Aluminum profiles(B1)-(1x)
- M4x16 Hex drive rounded head screws (4x)
- M4 Washer (4x)
- Extrusion assembly (E) (1x)
- Nozzle kit (N)-(1x). The wiring harness of component (N) and component (Ba) has already been connected.
- Timing belt(Be)-(1x)
- Pulley assembly(K2)-(1x)
- Belt tensioner(K1)-(1x)
- 2.5mm Allen key

Step 7. X-axis assembly (part 1)

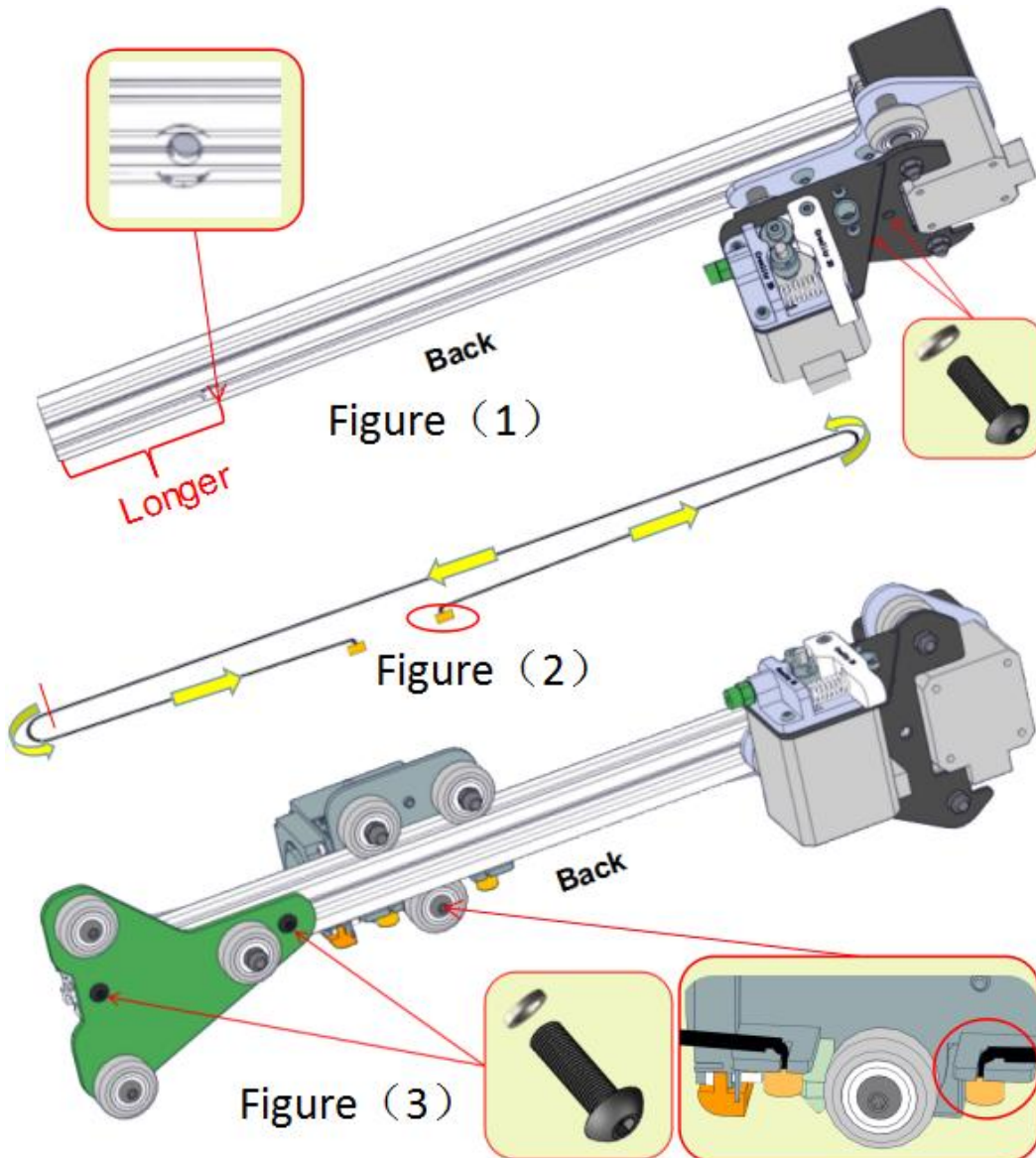

Step 1. Assembly of aluminum profile (B1) and extrusion assembly (E). Aluminum profile (B1) is shown in the diagram on the left(1). Pay attention to the position and direction of the large hole. Align the hole of extrusion assembly (E) with the threaded hole of aluminum profile (B1), it should be noted that the hole has two plates, which are secured with M4*16 screws, and fixed to the second profile plate and the aluminum profile (B1). Use a suitable Allen key to tighten the screws.

Step 2. Adjust the direction of the nozzle kit(N) as shown in Figure (3). Hold one end of the timing belt in the slot on the right side underneath the nozzle kit (N), and the other end in the path shown in Figure (2). Go through the extrusion assembly (E), bypass the synchronizing wheel, and slide the nozzle kit (N) from the left into the aluminum profile when the path of figure (2) completes three quarters (in the red line position in Figure 2). Then, complete the path of the belt as shown in Figure (2). Then, stick the other end of the belt to the slot on the left side below the nozzle kit (N).

Step 3. Position the pulley assembly (K2) in the position shown in Figure (3), align the threaded hole in the aluminum profile on the left side of the profile (B1), pass it with the M4*16 screw, and use the 2.5mm hexagon wrench to lock the screw;

Note. As you complete easy step, be sure to place the parts according to the diagram on the left side.

Step 8. X-axis assembly (Part 2)

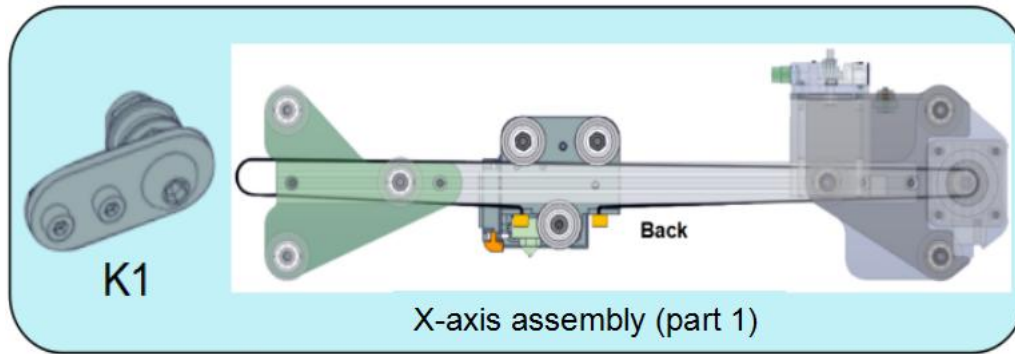

Step 1. Prepare belt tensioner assembly (K1) and 3mm Allen key.

Step 2. Rotate the X-axis assembly 180° horizontally.

Step 3. Pick up the belt tensioner assembly (K1). Loosen the T-nut by hand until it is at the end of the threads, but not so far it might fall off. Then, fit into the slot in the aluminum profile. When the bolt is tightened, the nut rotates 90 degrees and then grasps the inside of the slot.

Step 4. Align the T-nut with the top aluminum profile groove. Use an Allen key to tighten the screw. Be careful not to tighten it all the way. Make sure that the external actuator assembly (K1) can be slid easily.

Step 5. Align the belt so that one end fits over the geared pulley in the extrusion unit (E) and one end fits over the idler in the belt tensioning assembly (K1). Apply tension in the direction of the red arrow to the left and use an Allen key as a lever to push the belt around the pulley. Tighten the belt and then tighten the two screws.

Step 6. Check the tension of the belt driving the X-axis (on the gantry). The belt should be taut, with no slack or slop.

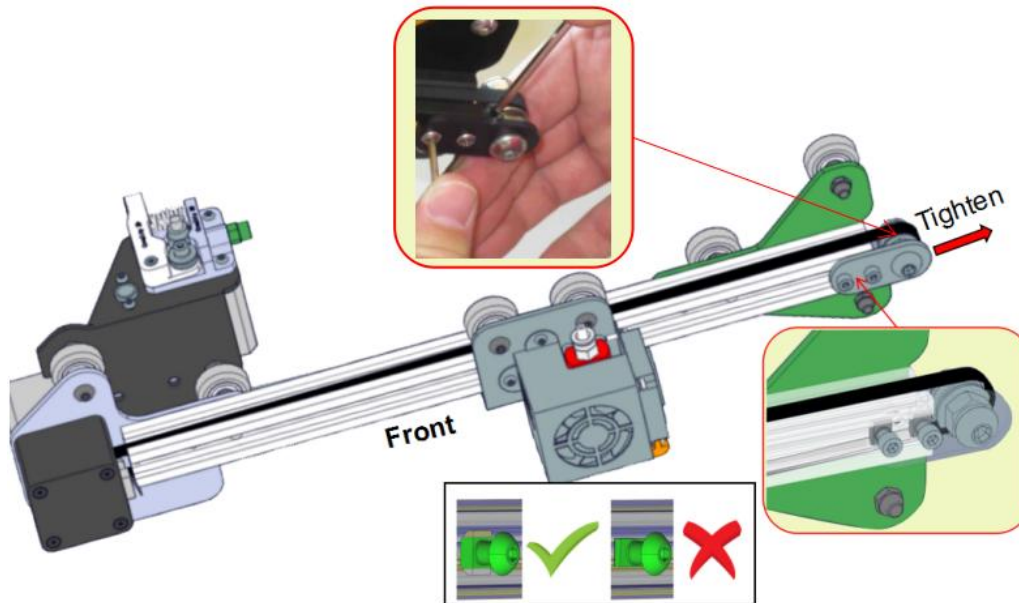

Step 9. X, Z bearing assembly

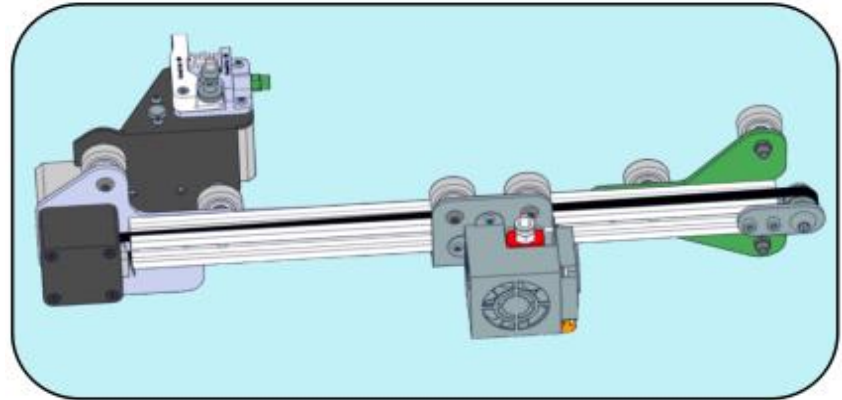
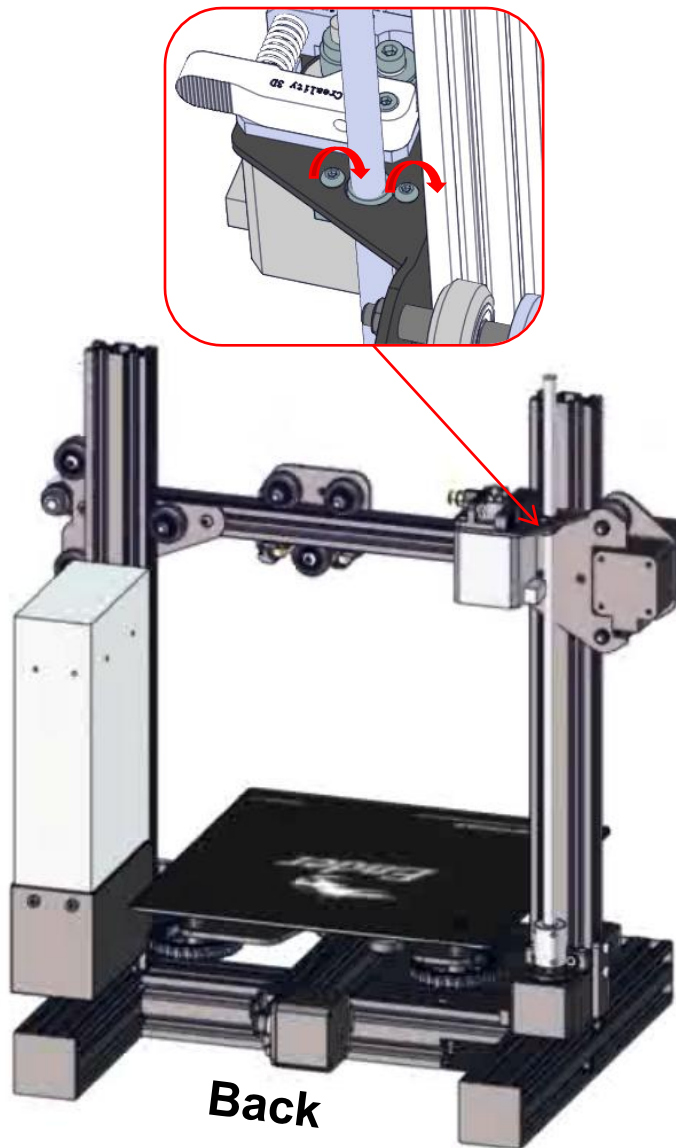

Step 1. Prepare 2mm and 2.5mm Allen key.

Step 2. The direction of the base (Ba) keeps the end in front and rotates the X-axis assembly horizontally by 180°.

Step 3. Align the pulleys on both ends of the X-axis assembly with the aluminum chute on the base (Ba). Align the screw rod with the nuts in the extrusion assembly (E). Use the appropriate Allen key to slightly loosen the screws that holding the nuts. Mount the X-axis assembly on the base (Ba)

Step 4. Manually apply force and slide the X-axis assembly up and down to slowly lock the screws that secure the nut.

Step 4. Slide the X-axis assembly up and down again to make sure the slide is smooth. If it is not smooth, try loosening the screws of the coupling slightly, turning the screws gently, and slowly tightening the screws.

Step 10. Fix the gantry frame

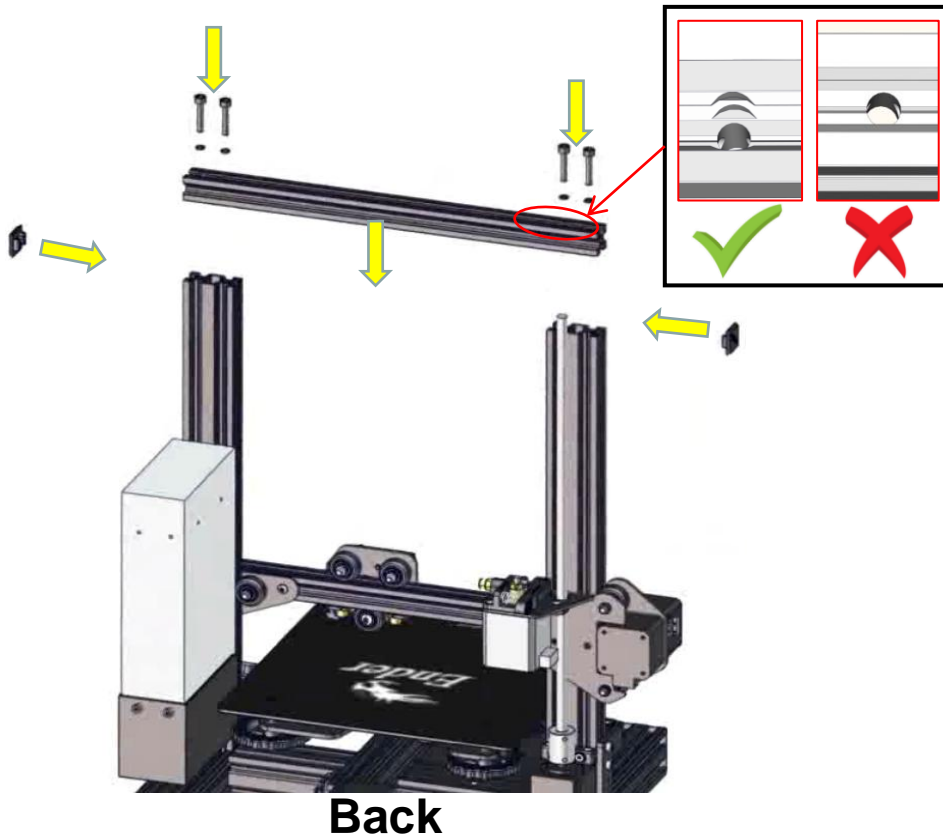
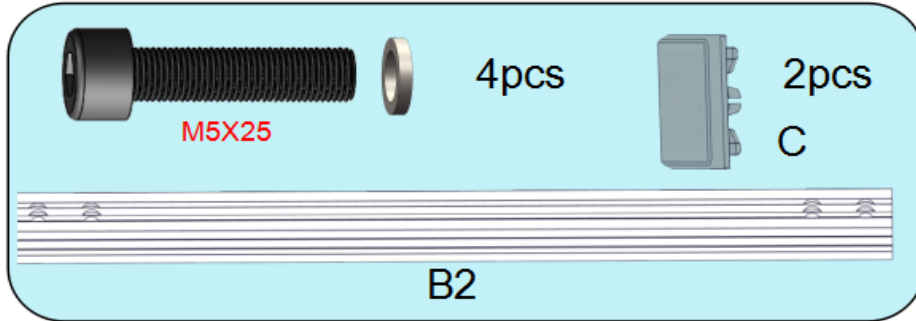

Prepare the following parts:

- M5x25 socket head hex screws (4x)
- M5 Washer (4x)
- Profile end caps(C)-(2x)
- Aluminum profiles (B2)-(1x)
- 4mm hexagon wrench

Step 1. Take out the aluminum profile (B2), pay attention to the counterbore hole at the top (see the figure on the left), align the aluminum profile (B2) hole with the threaded hole of the base (Ba), use the M5*25 screw and washer, from the top go through the aluminum profile hole(B2), use a 4mm Allen key to tighten the screws.

Step 2. Take out the end cover (C) of the profile, and attach it to the ends of the aluminum profile (B2). Apply a little pressure and insert it into it. The end face of the aluminum profile may be sharp. Be careful not to scratch your hand.

Step 11. Rack installation

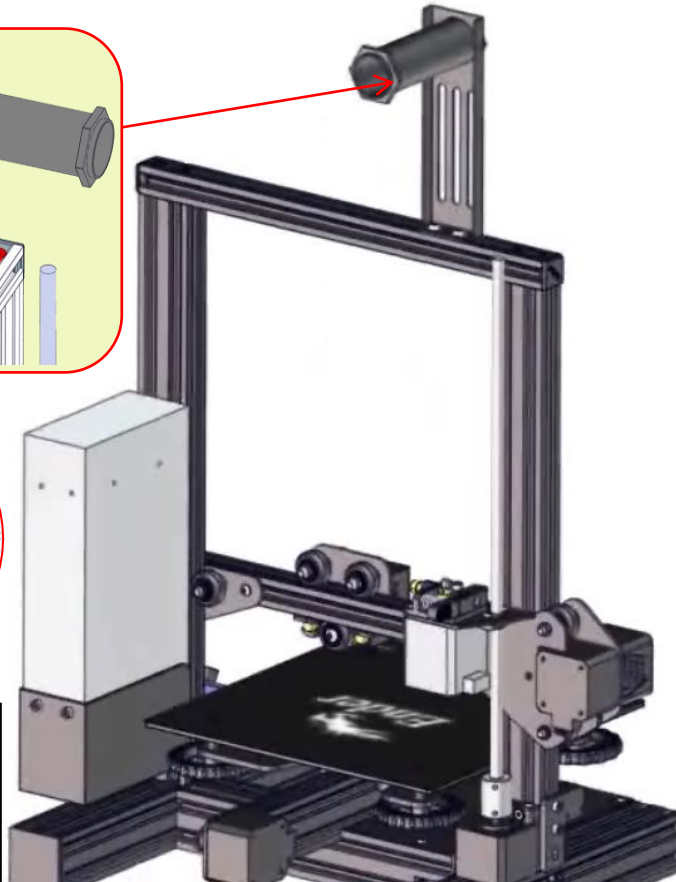
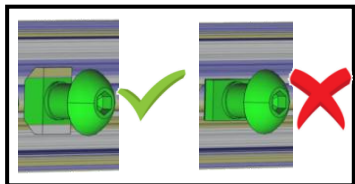
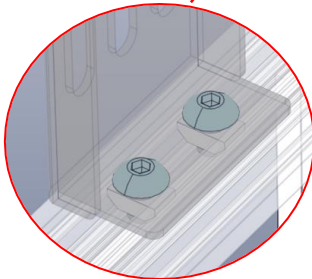
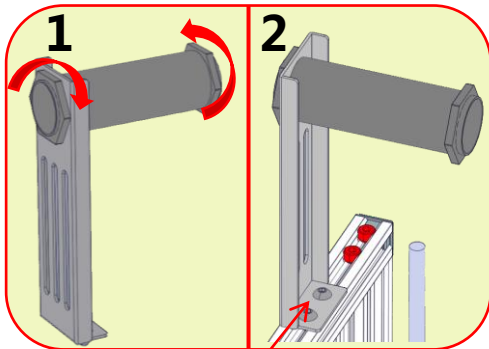
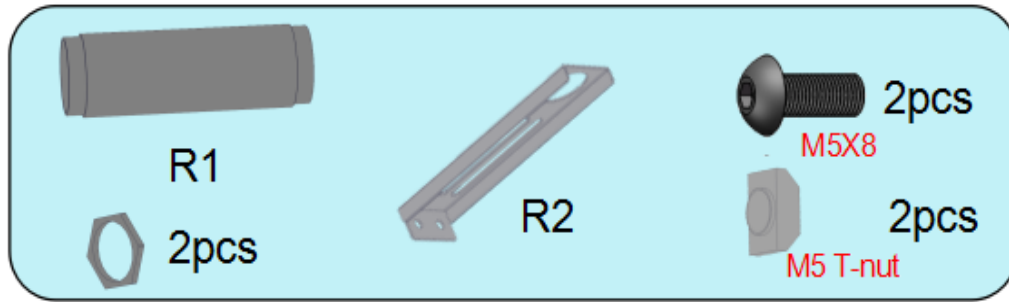

Prepare the following parts:

- Plastic tube (R1) -(1x)
- Plastic nut (2x)
- Sheet metal bracket (R2) - (2x)
- M5x8 Hex Drive Rounded Head Screws (2x)
- M5 T-nuts (2x)

f. 4mm Allen Key

Step 1. Install one end of the plastic tube (R1) on the sheet metal bracket (R2), hand-tighten the plastic nut on the end of the plastic tube (R1) and tighten by hand.

Step 2. Use a M5x8 screw to pass through the hole of the sheet metal bracket (R2). Hand-unscrew the M5 T-nut until it is on the last few threads of the screw.

Step 3. Align the T-nut with the top aluminum profile groove and tighten with an Allen key.

Step 4. The Ender-3 mechanical part installation has been completed.

Step 12. Tube and wire connection

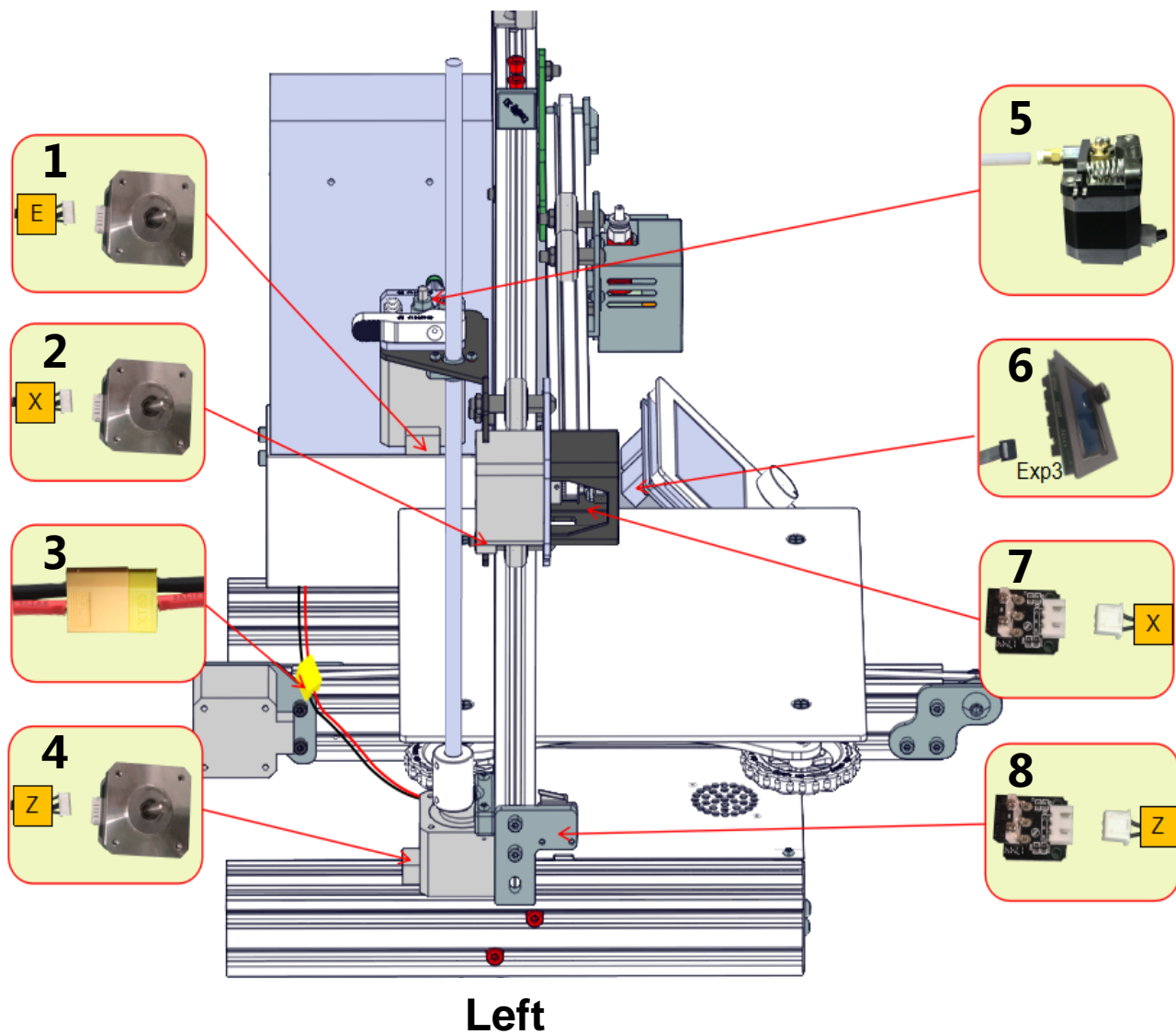

Step 1. Rotate the printer by 90°

Step 2. Find the letters on the 1/2/4/7/8 wire harnesses, as shown on the left, and insert it according to the position indicated by the red arrow on the drawing. After the insertion, gently pull on it to insure it's firmly seated. Note that the X/Z wide plug corresponds to the motor, and the narrow plug corresponds to the limit switch

Step 3. Red and black heated bed connector (3#) connector can be directly inserted.

Step 4. Connect the white PTFE Bowden tube from the hot end to the yellow tube upper coupler extruder (See 5#). Insert the tube firmly into the joint extruder and feel it slide in and lock the position.

Step 5. The plug on the 6# harness is inserted into the display board into the jack marked "Exp3."

Step 6. Check that all harnesses are securely connected.



Shenzhen Creality3D Technology CO.,LTD.

Official Website: www.creality3d.cn

Company Address: 12F, Building No.3, Jinchengyuan Industrial Area, Huafan Road,
Dalang, Longhua, Shenzhen, Guangdong Province

